

# High Profile Lit End Cap [SR-LENDCAP]

For use with Warmup WSR Self-Regulating Cable

[Non-hazardous and Hazardous Locations]



## Designed for Warmup WSR Self-Regulating Cable

Guarantees compatibility and optimal performance with Warmup's WSR self-regulating cable.

## Safe and Reliable End-Seal Connection

Ensures secure termination of Warmup's WSR Self-Regulating Cable, reducing risk of failure in critical applications.

## 360° Energised Indicator

360° visual indicator that activates when the cable is energised allowing operators to quickly and safely confirm circuit status.

## cCSAus Certified for Hazardous Locations

Guarantees compliance when used with WSR cable, making it suitable for a wide range of applications including hazardous areas.

## Overview

Warmup's High Profile Lit End Cap [SR-LENDCAP] is a specially designed kit for safe and reliable end termination of Warmup's WSR Self-Regulating Cable. It features a 360° indicator which activates when the cable is energised, allowing operators to verify circuit status externally.

The kit also features a supporting base which protects the heating cable and can be securely fastened to the pipe using stainless steel pipe straps. The Lit End Cap allows up to 80mm of pipe insulation.

The Lit End Cap is a cCSAus approved component for non-hazardous and hazardous locations when used with Warmup's WSR Self-Regulating Cable.

To maintain cCSAus compliance, only Warmup approved accessories may be used with WSR Self-Regulating Cable. Refer to the Part Numbers page for guidance.

# Kit Contents

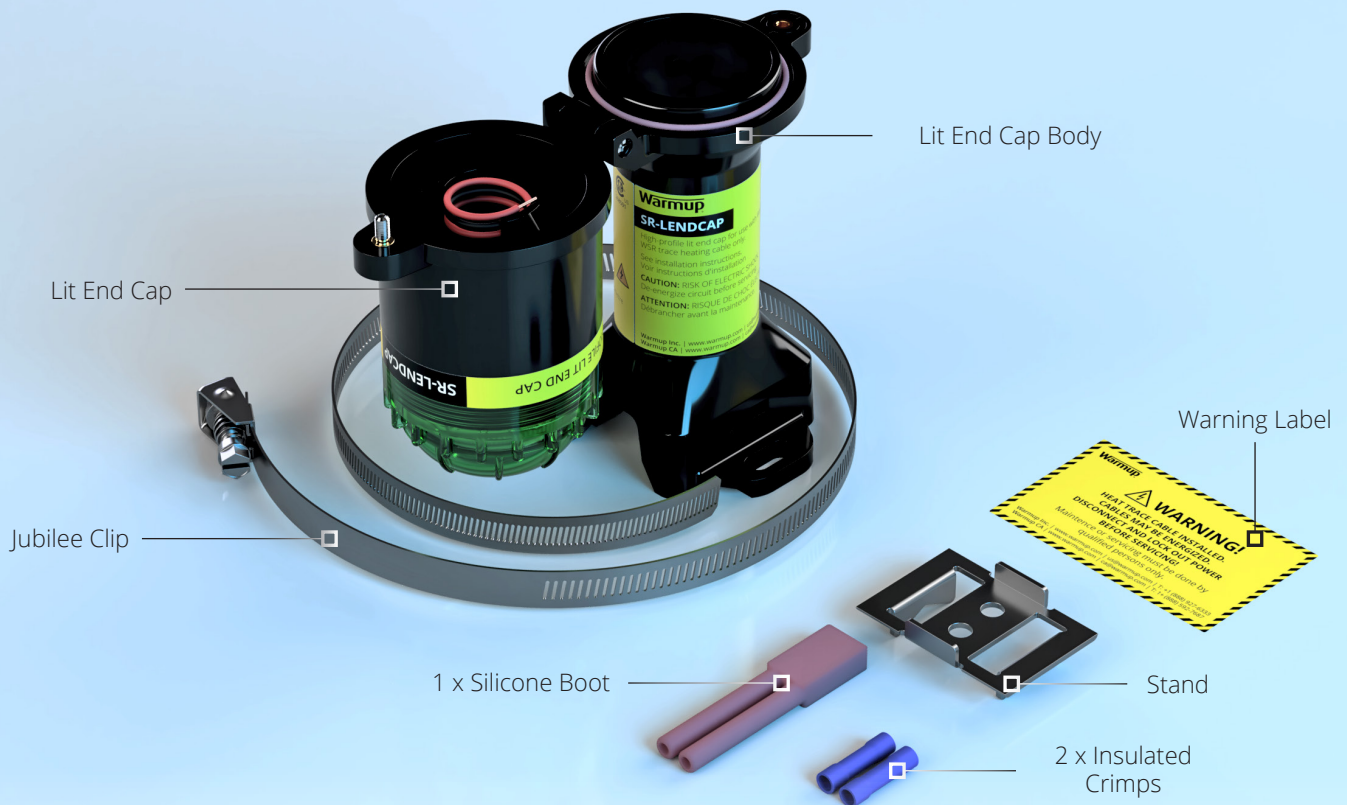

## SR-LENDCAP Approved Applications

Ordinary and Hazardous Locations †	Per US (NEC 500) and CA (CE Code Annex J18)	
	Class I, Division 2, Groups A, B, C and D, T5 / T6	Class II, Division 2, Groups F and G, T5 / T6
	Class III, T5 / T6	

† For hazardous locations, WSR heat trace cable MUST be installed with Warmup approved accessories for hazardous locations

# Technical Specifications

<b>Model</b>	SR-LENDCAP
<b>Operating Voltage</b>	120 V AC and 240 V AC
<b>Ambient Temperature Range (Ta)</b>	-40°F to +149°F (-40°C to +65°C)
<b>Protection Grade</b>	Type 4X; IP65
<b>Indicator Circuit Voltage</b>	9.8 V DC
<b>Indicator Amperage</b>	62mA Max.
<b>Minimum Installation Temperature</b>	-40°F (-40°C)
<b>Maximum Conductor Size</b>	14 AWG (2.5mm <sup>2</sup> ) multi-strand or solid
<b>Hazardous Locations Ratings Marking*</b>	Class I, Division 2, Groups A, B, C and D; T5 or T6
	Class II, Division 2, Groups F, G; T5 or T6;
	Class III; T5 or T6;
<b>Required Ground Fault Equipment Protection (GFEP)</b>	30mA
<b>Weight</b>	415g (14 5/8 oz)

\* For hazardous locations, WSR heat trace cable MUST be installed with Warmup approved accessories for hazardous locations

# Dimensions

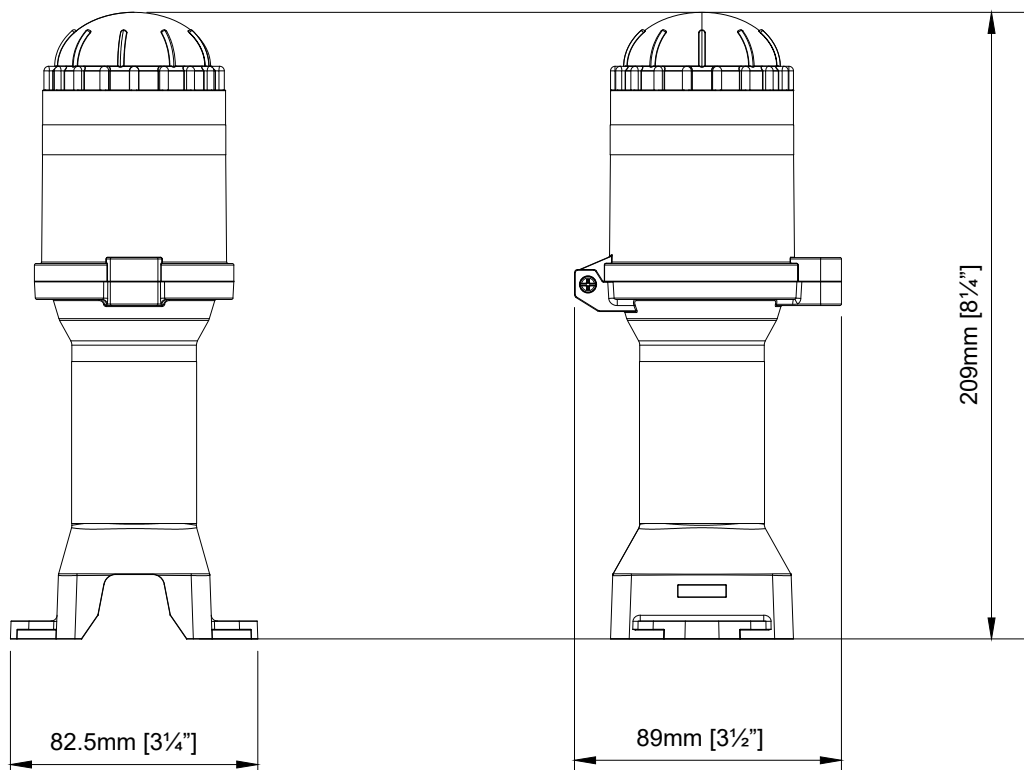

# Part Numbers

## WSR Self-Regulating Cable

Model	Code	Voltage	Cable Length	Power Output <i>W/ft insulated pipe @50°F (10°C); W/ft in water @32°F (0°C)</i>
WSR-5W-1-250-CR	WSR-5/9W-1-250-CR	110-120 VAC	250 ft	5.0 W/ft (8.9 W/ft)
WSR-5W-1-500-CR	WSR-5/9W-1-500-CR	110-120 VAC	500 ft	5.0 W/ft (8.9 W/ft)
WSR-5W-1-1000-CR	WSR-5/9W-1-1000-CR	110-120 VAC	1000 ft	5.0 W/ft (8.9 W/ft)
WSR-5W-2-250-CR	WSR-5/9W-2-250-CR	208-277 VAC	250 ft	5.0 W/ft (8.9 W/ft)
WSR-5W-2-500-CR	WSR-5/9W-2-500-CR	208-277 VAC	500 ft	5.0 W/ft (8.9 W/ft)
WSR-5W-2-1000-CR	WSR-5/9W-2-1000-CR	208-277 VAC	1000 ft	5.0 W/ft (8.9 W/ft)
WSR-8W-1-250-CR	WSR-8/12W-1-250-CR	110-120 VAC	250 ft	8.1 W/ft (12.8 W/ft)
WSR-8W-1-500-CR	WSR-8/12W-1-500-CR	110-120 VAC	500 ft	8.1 W/ft (12.8 W/ft)
WSR-8W-1-1000-CR	WSR-8/12W-1-1000-CR	110-120 VAC	1000 ft	8.1 W/ft (12.8 W/ft)
WSR-8W-2-250-CR	WSR-8/12W-2-250-CR	208-277 VAC	250 ft	8.1 W/ft (12.8 W/ft)
WSR-8W-2-500-CR	WSR-8/12W-2-500-CR	208-277 VAC	500 ft	8.1 W/ft (12.8 W/ft)
WSR-8W-2-1000-CR	WSR-8/12W-2-1000-CR	208-277 VAC	1000 ft	8.1 W/ft (12.8 W/ft)
WSR-10W-1-250-CR	WSR-10/15W-1-250-CR	110-120 VAC	250 ft	9.3 W/ft (15.3 W/ft)
WSR-10W-1-500-CR	WSR-10/15W-1-500-CR	110-120 VAC	500 ft	9.3 W/ft (15.3 W/ft)
WSR-10W-1-1000-CR	WSR-10/15W-1-1000-CR	110-120 VAC	1000 ft	9.3 W/ft (15.3 W/ft)
WSR-10W-2-250-CR	WSR-10/15W-2-250-CR	208-277 VAC	250 ft	9.3 W/ft (15.3 W/ft)
WSR-10W-2-500-CR	WSR-10/15W-2-500-CR	208-277 VAC	500 ft	9.3 W/ft (15.3 W/ft)
WSR-10W-2-1000-CR	WSR-10/15W-2-1000-CR	208-277 VAC	1000 ft	9.3 W/ft (15.3 W/ft)

## WSR Approved Accessories

Model	Description	Classification	Application
SR-SFIT-BOX-S	Power Connection Box for connecting WSR to supply	<b>Non-Hazardous &amp; Hazardous Locations</b> <i>Ex eb IIC T3 Gb, Ex tb IIIC T200°C Db Class I, Zone 1, AEx eb IIC T3 Gb Class II, Zone 21, AEx tb IIIC T200°C Db Class I, Division 2, Groups A, B, C and D T3 Class II, Division 2, Groups F, G T3</i>	Pipe Tracing Roof & Gutter
SR-SFIT-SPL	Splice Connection kit for In-line Splice of WSR cable		
SR-SFIT-TEE	Tee Splice Connection kit for Tee Splice of WSR cable		
SR-END-KIT	End-Seal Termination kit for WSR cable termination		
SR-LENDCAP	Lighted End Kit for WSR cable termination, giving visual indicator when WSR cable is active. <b>Certified for use at 120 or 240V AC only.</b>	<b>Non-Hazardous &amp; Hazardous Locations</b> <i>Class I, Division 2, Groups A, B, C and D; Class II, Division 2, Groups F and G; Class III; T5 or T6</i>	Pipe Tracing Roof & Gutter
SR-POWER-KIT	Power Connection Kit for WSR cable, incl. components for 1 power connection, 1 termination. Incl. 1 pipe standoff bracket.	<b>Non-Hazardous Locations</b>	Pipe Tracing Roof & Gutter
CRDS-15-GFCI	Plug-in, ground-fault-circuit interrupter [GFCI] power connection kit with 5-15P type plug for Warmup's WSR <b>120V Self-Regulating Cable</b>	<b>Non-Hazardous Locations</b>	Pipe Tracing Roof & Gutter
SR-SPLICE-KIT	Splice/Tee Kit for WSR cable. Incl. components for 1 Splice and 1 End Seal, or 1 Tee Connection and 1 End Seal	<b>Non-Hazardous Locations</b>	Pipe Tracing Roof & Gutter
SR-ROOF-CLIP(50/BAG)	Metal single roof clips (50/BAG) to secure WSR cable	<b>Non-Hazardous Locations</b>	Roof & Gutter
SR-HANGER-KIT	Downspout Hanger for WSR cable	<b>Non-Hazardous Locations</b>	Roof & Gutter

# Product Markings

<b>Trade mark; Product type</b>	WARMUP	
<b>Model</b>	SR-LENDCAP	
<b>Warning Information</b>	High-profile lit end cap for use with Warmup WSR trace heating cable only. See installation instructions.Voir instructions d'installation CAUTION: RISK OF ELECTRIC SHOCK. De-energize circuit before servicing. ATTENTION: RISQUE DE CHOC ÉLECTRIQUE. Débrancher avant la maintenance.	
<b>Voltage Rating</b>	120 V AC and 240 V AC	
<b>Ambient Temperature Range (Ta)</b>	-40°F to +149°F (- 40°C to + 65°C)	
<b>Protection Grade</b>	Type 4X; IP65	
<b>Hazardous Locations Ratings Marking*</b>	Class I, Division 2, Groups A, B, C and D; T5 or T6	
	Class II, Division 2, Groups F, G; T5 or T6;	
	Class III; T5 or T6;	
<b>Approvals</b>	 CSA Approved Canada & USA	<b>268591</b>
		CSA File Number

## Contact

Warmup is available 24/7/365 at (888) 927-6333  
 For quotes, layouts and specific technical information contact us at:

**Warmup Inc**  
 www.warmup.com  
 us@warmup.com  
 T: +1 (888) 927-6333

**Warmup Canada**  
 www.warmup.com  
 ca@warmup.com  
 T: 1+ (888) 592-7687

25 Francis J Clarke Cir, Bethel,  
 CT 06801

Please be advised Warmup Inc., provides these technical specifications and or instructions on a self help basis. We take every precaution to ensure they are accurate. Some of the products are sourced from manufacturers and we relay that information on to you. We do not have the technical specifications reviewed by an engineer and sometimes errors do happen. Our products are only reviewed with an ordinary level of care and when using said products in a situation that warrants additional care please be sure to conduct your own review. As such we strongly suggest before installing our products you have them reviewed by a professional engineer or qualified professional. We under no circumstances warrant our products for a particular use unless specifically agreed in writing.

# Guide to Hazardous Locations\*

---

## A Class I, Division 2 location is a location:

- (i) In which volatile flammable gases, flammable liquid-produced vapors, or combustible liquid-produced vapors are handled, processed, or used, but in which the liquids, vapors, or gases will normally be confined within closed containers or closed systems from which they can escape only in case of accidental rupture or breakdown of such containers or systems or in case of abnormal operation of equipment, or
- (ii) In which ignitable concentrations of flammable gases, flammable liquid-produced vapors, or combustible liquid-produced vapors are normally prevented by positive mechanical ventilation and which might become hazardous through failure or abnormal operation of the ventilating equipment, or
- (iii) That is adjacent to a Class I, Division 1 location, and to which ignitable concentrations of flammable gases, flammable liquid-produced vapors, or combustible liquid-produced vapors above their flash points might occasionally be communicated unless such communication is prevented by adequate positive-pressure ventilation from a source of clean air and effective safeguards against ventilation failure are provided.

---

## Class I Group Classifications

**A** Acetylene

**B** Flammable gas, flammable liquid-produced vapor, or combustible liquid-produced vapor mixed with air that may burn or explode, having either a maximum experimental safe gap (MESG) value less than or equal to 0.45 mm or a minimum igniting current ratio (MIC ratio) less than or equal to 0.40

**C** Flammable gas, flammable liquid-produced vapor, or combustible liquid-produced vapor mixed with air that may burn or explode, having either a maximum experimental safe gap (MESG) value greater than 0.45 mm and less than or equal to 0.75 mm, or a minimum igniting current (MIC) ratio greater than 0.40 and less than or equal to 0.80.

**D** Flammable gas, flammable liquid-produced vapor, or combustible liquid-produced vapor mixed with air that may burn or explode, having either a maximum experimental safe gap (MESG) value greater than 0.75 mm or a minimum igniting current (MIC) ratio greater than 0.80.

---

## A Class II, Division 2 location is a location:

- (i) In which combustible dust due to abnormal operations may be present in the air in quantities sufficient to produce explosive or ignitable mixtures; or
- (ii) Where combustible dust accumulations are present but are normally insufficient to interfere with the normal operation of electrical equipment or other apparatus, but could as a result of infrequent malfunctioning of handling or processing equipment become suspended in the air; or
- (iii) In which combustible dust accumulations on, in, or in the vicinity of the electrical equipment could be sufficient to interfere with the safe dissipation of heat from electrical equipment, or could be ignitable by abnormal operation or failure of electrical equipment.

---

## Class II Combustible Dust Group Classifications

**F** Atmospheres containing combustible carbonaceous dusts that have more than 8 percent total entrapped volatiles (see ASTM D3175-2017, Standard Test Method for Volatile Matter in the Analysis Sample of Coal and Coke, for coal and coke dusts) or that have been sensitized by other materials so that they present an explosion hazard. [499:3.3.9.1.2] Although coal, carbon black, charcoal, and coke dusts are examples of carbonaceous dusts only those atmospheres containing combustible carbonaceous dust that have more than 8 percent total entrapped volatiles are Class II, Group F.

**G** Atmospheres containing combustible dusts not included in Group E or Group F, including flour, grain, wood, plastic, and chemicals.

---

## Equipment Temperature Class

The temperature class or operating temperature at a 104°F (40°C) ambient temperature, or at the higher ambient temperature if the equipment is rated and marked for an ambient temperature of greater than 104°F (40°C).

**T3** = ≤ 392°F (≤ 200°C); **T5** = 212°F (≤ 100°C); **T6** = ≤ 185°F (≤ 85°C)

---

## A Zone 1 location is a location

- (i) In which ignitable concentrations of flammable gases or vapors are likely to exist under normal operating conditions; or
- (ii) In which ignitable concentrations of flammable gases or vapors may exist frequently because of repair or maintenance operations or because of leakage; or
- (iii) In which equipment is operated or processes are carried on, of such a nature that equipment breakdown or faulty operations could result in the release of ignitable concentrations of flammable gases or vapors and also cause simultaneous failure of electrical equipment in a mode to cause the electrical equipment to become a source of ignition; or
- (iv) That is adjacent to a Zone 0 location from which ignitable concentrations of vapors could be communicated, unless communication is prevented by adequate positive pressure ventilation from a source of clean air and effective safeguards against ventilation failure are provided.

# Guide to Hazardous Locations\*

---

## A Zone 21 location is a location where one of the following apply:

- (i) Ignitable concentrations of combustible dust, combustible fibers/flyings, or ignitable fibers/flyings are likely to exist occasionally under normal operating conditions.
- (ii) Ignitable concentrations of combustible dust, combustible fibers/flyings, or ignitable fibers/flyings might exist frequently because of repair or maintenance operations or because of leakage.
- (iii) Equipment is operated or processes are carried on of such a nature that equipment breakdown or faulty operations could result in the release of ignitable concentrations of combustible dust, combustible fibers/flyings, or ignitable fibers/flyings and also cause simultaneous failure of electrical equipment in a mode to cause the electrical equipment to become a source of ignition.
- (iii) The location is adjacent to a Zone 20 location from which ignitable concentrations of combustible dust, combustible fibers/flyings, or ignitable fibers/flyings could be communicated.  
*Exception: When communication from an adjacent Zone 20 location is minimized by adequate positive pressure ventilation from a source of clean air, and effective safeguards against ventilation failure are provided.*
- (iv) Group IIIC combustible dusts are present in hazardous quantities occasionally, under normal or abnormal operating conditions, or frequently because of repair or maintenance operations or because of leakage.

---

## Symbols explained

**AEx** The symbol AEx identifies the equipment as meeting American national standards. The symbol Ex is used in European Union countries. Only equipment marked AEx has been evaluated for use in electrical systems and hazardous locations covered by the NEC

---

## Equipment Suitable for Hazardous (Classified) Locations

Mark	NEC Area Classification	Type (Level) of Protection
<b>eb</b>	Zone 1	Increased safety (Group II)
<b>tb</b>	Zone 21	Protection by enclosure (Group III)

---

## Equipment Protection Level

The EPL indicates the level of protection provided by the equipment and is correlated to the zone in which the equipment will be installed and operated.

Mark	NEC Area Classification	Type (Level) of Protection
<b>Gb</b>	Zone 1	equipment for explosive gas atmospheres, having a "high" Level of Protection, which is not a source of ignition in normal operation or during expected malfunctions
<b>Db</b>	Zone 21	equipment for explosive dust atmospheres, having a "high" Level of Protection, which is not a source of ignition in normal operation or during expected malfunctions

---

## Material Groups

**IIC** Group IIC: Atmospheres containing acetylene, hydrogen, or flammable gas, flammable liquid-produced vapor, or combustible liquid-produced vapor mixed with air that may burn or explode, having either a maximum experimental safe gap (MESG) value less than or equal to 0.50 mm or minimum igniting current (MIC) ratio less than or equal to 0.45.

**IIIC** Group IIIC: Combustible metal dust, including combustible metal fibers/flyings.

*Equipment marked Group IIIC shall be permitted for applications requiring Group IIIA or Group IIIB equipment.*

---

## IECEx/ATEX standards

**Ex** The symbol Ex is used in European Union countries.

**60079-30-1** STANDARD FOR SAFETY  
Explosive Atmospheres – Part 30-1: Electrical Resistance Trace Heating – General and Testing Requirements

---

\* This guide is provided for reference purposes only. It summarizes typical classifications and installation types based on information from the National Electrical Code (NEC), Canadian Electrical Code (CEC), and relevant international standards.

**This guide does not replace or supersede any official code or standard.** For the most accurate and up-to-date requirements, always consult the NEC, CEC, and applicable local regulations, as well as the latest versions of IECEx/ATEX standards. Installation in hazardous locations must comply with all certification conditions and use only Warmup approved accessories as specified in the product documentation.