



High Profile Lit End Cap Installation Instructions

(SR-LENDCAP)

For use with Warmup WSR Parallel Self-Regulating Cable
Non-hazardous and hazardous locations

Model	WSR- <a> W- <c> - <XXX> d				
Code	WSR- <a> W- <c> - <XXX> d				
	<a> = 5, 8, 10 W/ft W/ft insulated pipe @50°F (10°C)	 = 9, 12, 15 W/ft W/ft in water @32°F (0°C)	<c> = 1 / 2 1 = 110-120 V AC 2 = 208-277 V AC	<XXX> = 250, 500 or 1000ft Cable length	<d> = CR Outer jacket material

Kit & Cable Description

Warmup's High Profile Lit End Cap [SR-LENDCAP] is a specially designed kit for safe and reliable end termination of Warmup's WSR Self-Regulating Cable. It features a 360° indicator which activates when the cable is energised, allowing operators to verify circuit status externally.

Warmup's WSR self-regulating cable features an advanced positive temperature coefficient [PTC] self-regulating core is positioned between two 16 AWG multi-strand tinned copper bus wires. These are then insulated with a modified polyolefin layer which is wrapped in a tinned copper braid for grounding.

The cable's outer jacket, made from modified polyolefin, ensures superior resistance to UV, abrasion, chemical, and mechanical wear, enhancing durability in harsh conditions.







SR-LENDCAP - Approved Applications



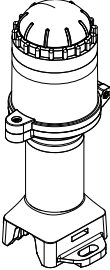

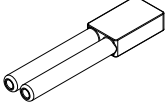
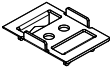
Ordinary and Hazardous Locations †	Per US (NEC 500) and CA (CE Code Annex J18)	
	Class I, Division 2, Groups A, B, C and D, T5 / T6	Class II, Division 2, Groups F and G, T5 / T6
	Class III, T5 / T6	

† For hazardous locations, WSR heat trace cable MUST be installed with Warmup approved accessories for hazardous locations

Kit Components

1 x SR-LENDCAP		1 x Jubilee Clip		1 x Silicone boot	
1 x Stand		2 x Insulated crimps 1/4" x 1" 6.3 x 24.3mm		1 x Warning label	

Receiving, Storing And Handling

-  Identify components against the packing list to ensure the proper type and quantity has been received check corresponding documentation.
-  Inspect components for damage incurred during shipping.
-  Components should be checked to verify catalogue type, power rating, voltage rating, and quantity.
-  Components should be examined to verify compatibility with the environmental elements that might be encountered. Special consideration should be given to the area of installation (indoor versus outdoor) and where applicable, the components should be appropriately rated for the intended application. Refer to the kit markings.
-  Components should be stored in clean, dry areas and should not be released to the field until they are needed for construction so as to minimize inadvertent damage.

Tools Required For Installation

- Pliers
- Screwdriver
- Wire cutters
- Crimping Tool
- Utility knife
- Measuring tape
- Glass cloth tape



Please read these instructions carefully before beginning installation.
Failure to do so could result in electric shock or fire.
CAUTION: Risk of electric shock-disconnect the electric power before servicing
ATTENTION : Risque de choc électrique-débrancher avant la maintenance
CAUTION: a ground fault protection device must be used with this heating device
ATTENTION : ce produit doit être utilisé avec une protection de mise à la terre

-  Before installation, servicing or maintenance, the cables MUST be de-energised. The branch-circuit switch or circuit breaker supplying the equipment shall be placed in the OPEN (OFF) position and secured with a lockout device. This lockable disconnecting means shall simultaneously disconnect all ungrounded conductors and must comply with NEC/CEC requirements.
-  To reduce the risk of shock or fire ground-fault equipment protection with a 30mA trip level must be installed on each heating cable branch circuit. Ground-fault equipment protective devices intended for use with self-regulating heating cable circuits in Division areas shall be appropriately identified for use in Division areas.
-  The self-regulating cable and its components must be installed in accordance with the National Electrical Code [NEC] and Canadian Electrical Code [CEC] and any other applicable national and local codes. Review their requirements prior to installation.
-  When installation is complete, an insulation resistance test should be conducted with a test voltage of at least 500 V dc using a megohmmeter between the self-regulating cable bus wires and the metallic braid. IEEE 515.1 recommends that the test voltage for polymer insulated heating cables be 2500 Vdc. Minimum resistance should be 20 MΩ. After the application of thermal insulation, the measured value of the entire branch circuit should not be less than 5 MΩ.
-  The tinned copper braid must be connected to a suitable grounding/earthing terminal.
-  The equipment [cable and components] shall not be installed in a location where the external conditions are conducive to the build-up of electrostatic charge on such surfaces. In addition, the equipment shall only be cleaned with a damp cloth and shall be cleaned regularly to prevent dust accumulation.
-  Bus wires will short if they contact each other. Keep bus wires separated. Damage to the bus wires can result in overheating or short circuits. Take care when removing the jacket or core insulation to prevent damage to the braid or bus wires.
-  **WARNING:** Do not replace or substitute components. Only the components supplied in the SR-LEND CAP are approved for use. Using incorrect components may cause leaks, damage to components, electric shock, or dielectric failure, and will void all approvals, certifications and suitability for Class I Division 2.
-  Ensure you have the correct type of Warmup components for your installation. To maintain cCSAus compliance, only Warmup approved components may be used with WSR Self-Regulating Cable.
-  The equipment [cable and components] shall be installed such that the cable is protected from mechanical damage. The cable shall not be subjected to tension or torque. If the cable is to be terminated within an explosive atmosphere, then the free end shall be terminated in a suitably certified termination. Junction boxes shall be installed in a low mechanical risk position.
-  Ensure that you have the correct type and size of self-regulating cable for your installation (wattage output and voltage rating). Ensure that connection kits and cable ends are kept dry before and during installation.
-  Connections should not be located in an area where moisture is present.
-  The minimum bending radius of the cable is 1¼" (30 mm). Do not bend on the narrow axis.
-  DO NOT connect power to the cable while it is on the reel.
-  The minimum installation temperature for the cable is -4°F (-20°C) when use with integral component kits and -40°F (-40°C) when use with enclosure kits.
-  The presence of the self-regulating cable shall be made evident by the posting of warning signs where clearly visible. For Roof & Gutter applications apply with supplied warning label on circuit breaker panels, contactor panels and junction boxes. For Pipe Trace applications, warning labels at intervals not exceeding 6 m (20 ft) along the pipeline or vessel and on or adjacent to equipment in the piping system that requires periodic servicing.
-  Persons involved in the installation, testing and maintenance of self-regulating heating systems shall be suitably trained in all special techniques required. Installations are intended to be carried out under the supervision of a qualified persons.
-  The person(s) responsible for installation shall verify that the installation and inspection are performed by personnel who are trained, qualified, and knowledgeable in trace heating systems when using the Division/Zone method of area classification. The installation and inspection shall be in accordance with Warmup's design documents, product recommendations, and installation instructions.
-  The proposed installation shall be verified for the proper selection of self-regulating cable and component systems identified for the application; i.e. Class and Division/Zone. Warmup's documentation shall be reviewed for specific installation requirements and the proposed installation shall be verified that the heating system is compatible with the environment.
-  Leave these installation instructions with the user for future reference. The self-regulating heating system [cable and components] documentation shall be retained for each self-regulating heating circuit for as long as the system is in use.
-  The SR-LEND CAP instructions must be used with reference to the installation instructions for the WSR Self-Regulating cable.

Installation

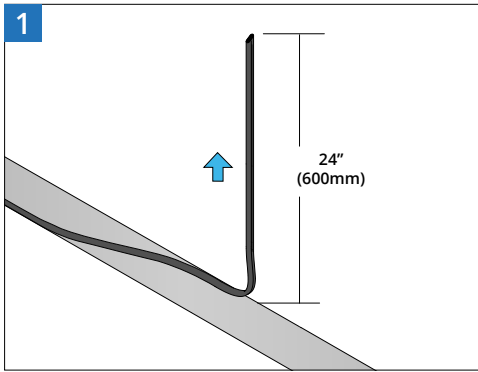

- Leave excess cable as shown to ensure there is sufficient cable to allow for an easier install and to provide excess cable for any future electrical works.

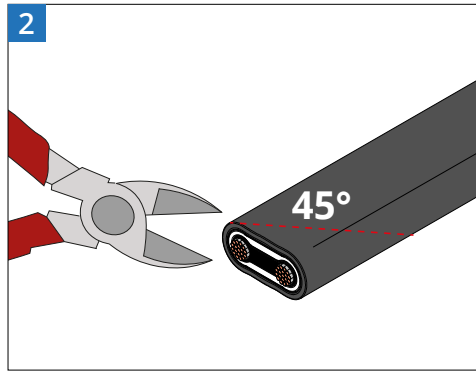

- Cut the end of the cable at a 45° angle as this will help when feeding the cables through the watertight sealing grommet.

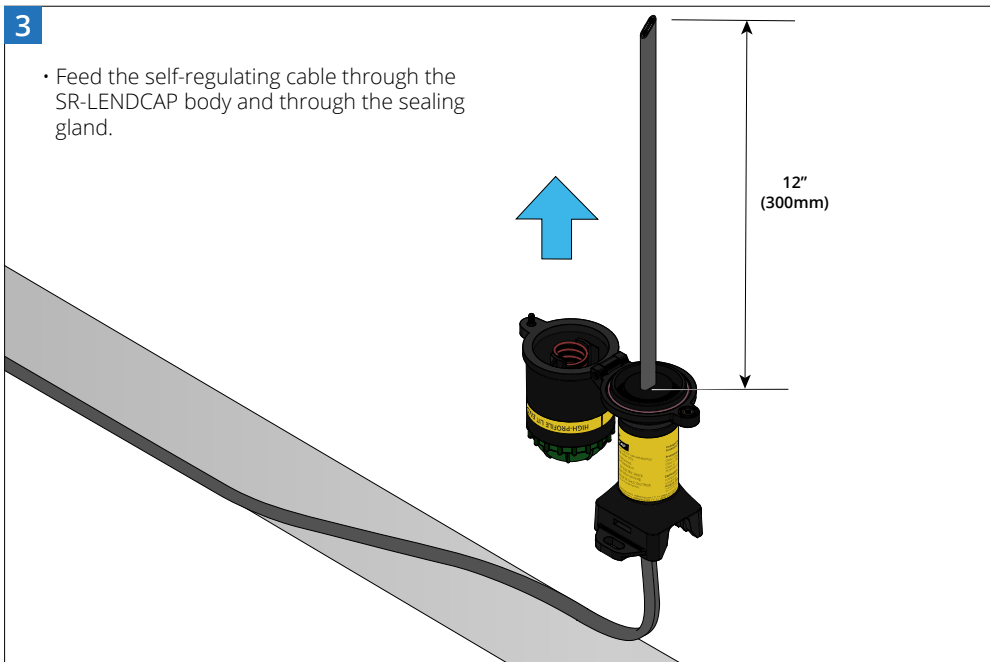

- Feed the self-regulating cable through the SR-LENDCAP body and through the sealing gland.

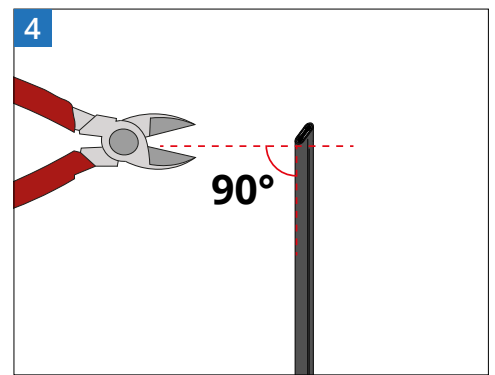

- Cut the ends of the cables square, ready to begin removal of the outer jacket.

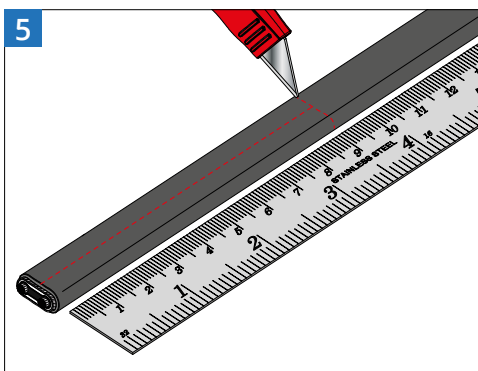

- Measure and mark approximately 3½" (90mm) from the end of the cable on the outer jacket.
- Lightly score the outer jacket as shown, ensuring you DO NOT cut the ground braid or inner jacket. Bend the cable to break the outer jacket.

NOTE: It is better to do multiple shallow scores to the outer jacket than go too deep and cut the braid.

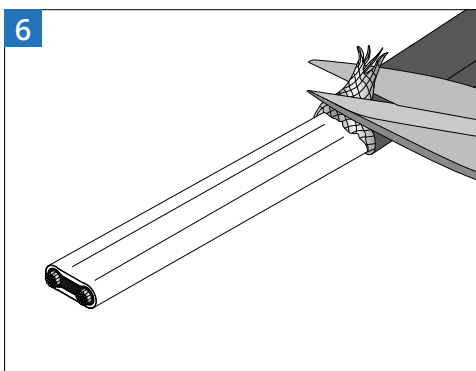

- Remove excess ground braid.

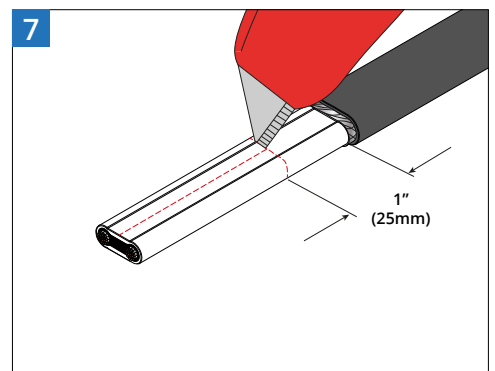

- Measure and mark approximately ¾" (20mm) from the outer insulation up the inner insulation.
- Slice and remove the inner insulation layer as shown. Bend the cable to break the inner jacket.

Installation

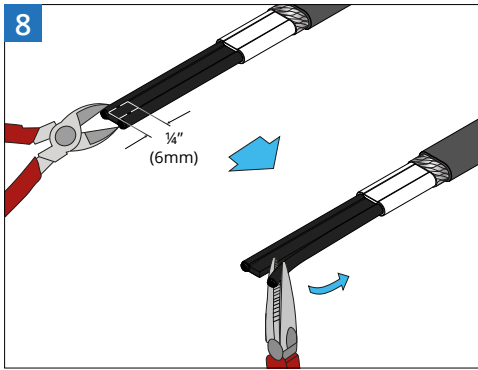

- Using wire cutters, create a 1/4" (6mm) cut as close to and parallel with the bus wires.
- Using pliers, peel back the bus wire from the exposed length of self-regulating conductive core down to the inner insulation.

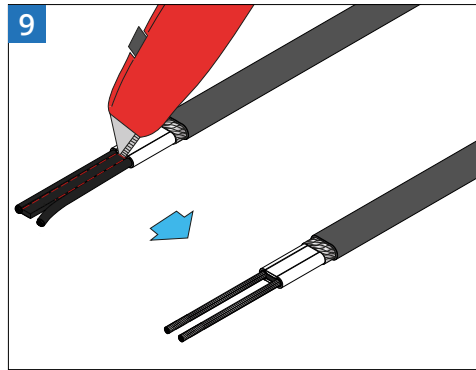

- Carefully slice and remove the self-regulating conductive core with the utility knife, ensuring you DO NOT CUT the bus wires.
- Ensure all of the core and any remaining materials are removed from the bus wires.

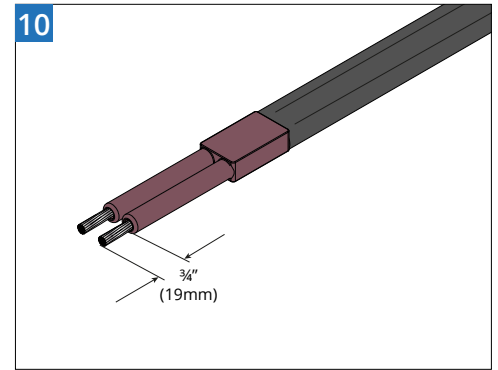

- Slide the silicone boot onto the bus wires.
- Cut the bus wires so that extend 3/4" (19mm) from the end of the boot.

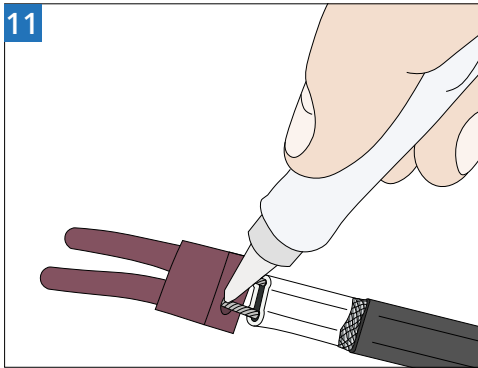

- Seal the ends of the silicone boot with a natural cure, single part RTV adhesive.

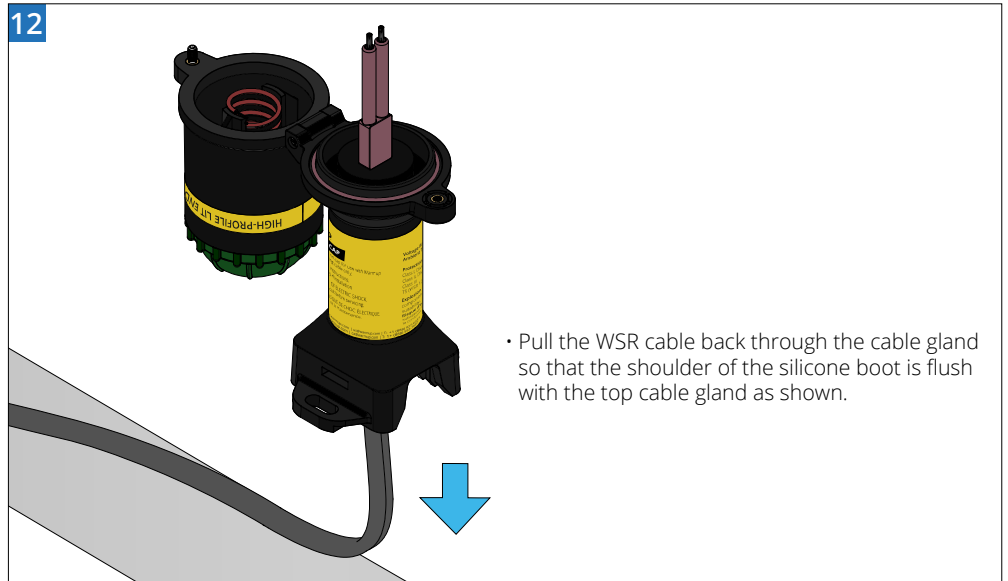

- Pull the WSR cable back through the cable gland so that the shoulder of the silicone boot is flush with the top cable gland as shown.

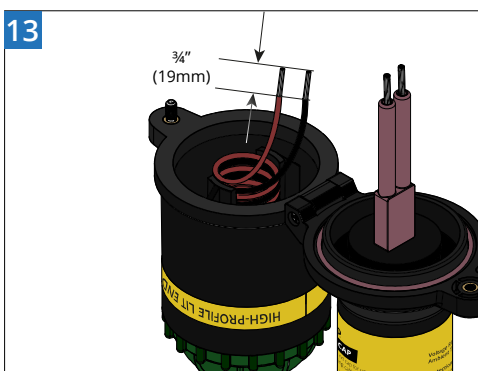

- Strip the cables in the lit end cap so that there is 3/4" (19mm) of exposed conductor.

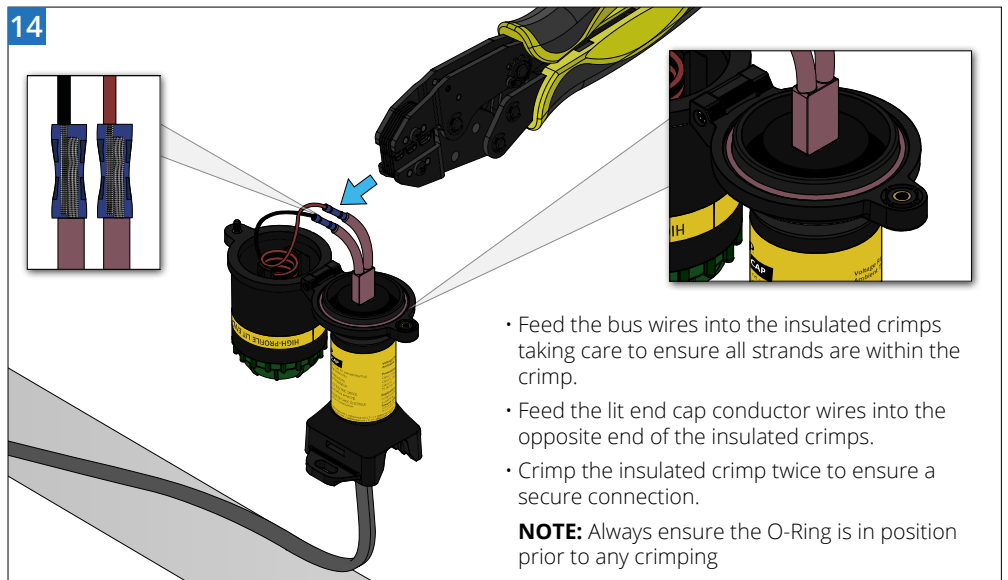

- Feed the bus wires into the insulated crimps taking care to ensure all strands are within the crimp.
- Feed the lit end cap conductor wires into the opposite end of the insulated crimps.
- Crimp the insulated crimp twice to ensure a secure connection.

NOTE: Always ensure the O-Ring is in position prior to any crimping

Installation

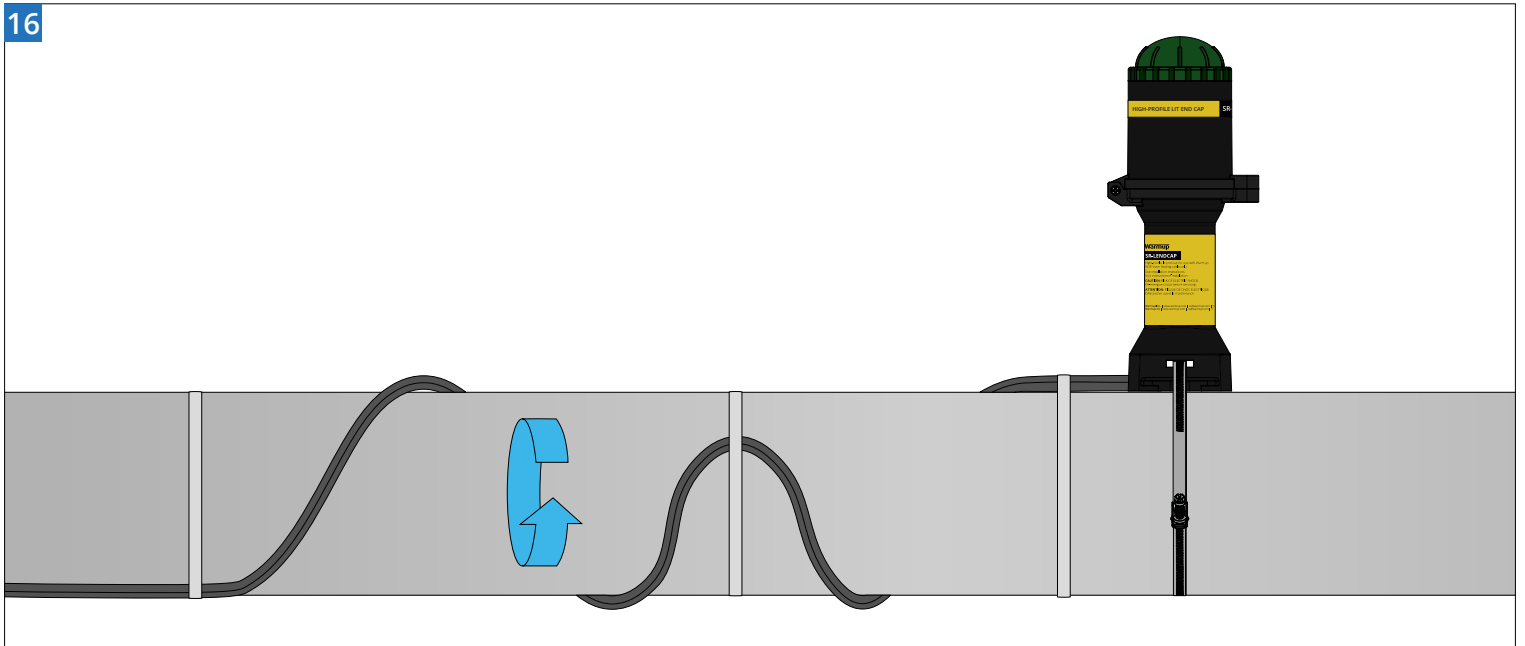
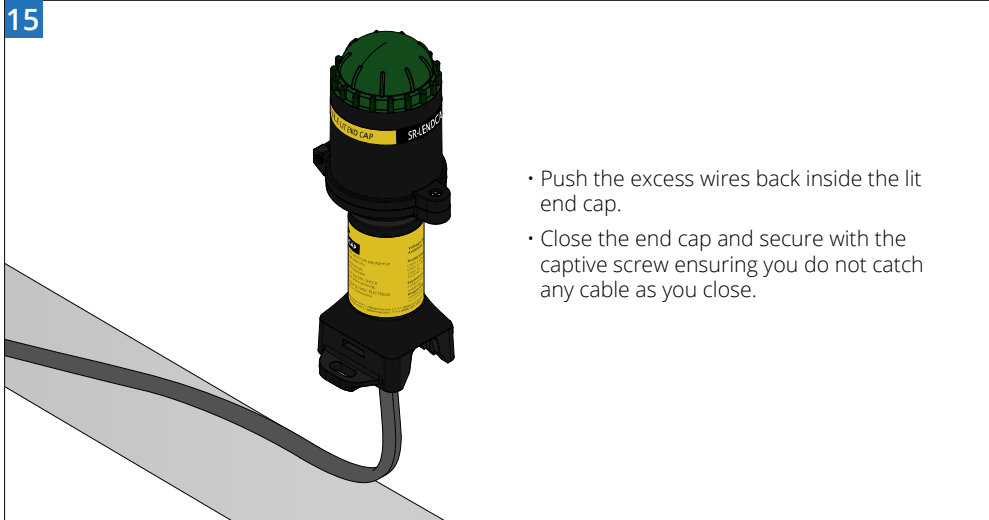

- Secure the SR-LEND CAP to the pipe using the supplied pipe strap.
- Wrap the excess self-regulating cable around the pipe as shown to provide strain relief to the cable entering the SR-LEND CAP.
- Secure the self-regulating cable to the pipe at the locations shown to also provide additional strain relief. Use glass cloth tape to secure the cable to the pipe.

 You **MUST** provide additional and effective clamping of the cable to ensure that pulling is not transmitted to the terminations and prevent pulling and twisting after installation.

Maintenance

A system inspection for freeze protection systems is recommended before the winter season. Category II systems should be inspected annually. All observations and measured values (as appropriate) should be recorded on a log sheet.

Caution: Always consult the self-regulating cable heating system documentation [cable & components] prior to maintenance / repair / modification.

The full maintenance requirements, including maintenance log sheet, are detailed in the WSR Self-Regulating cable manual. The SR-LENDCAP instructions must be used with reference to the installation instructions for the WSR Self-Regulating cable manual. Some maintenance procedures for the SR-LENDCAP include:



Junction boxes should be checked to verify that they are free of moisture and water. The thermal insulation and weather barrier should be inspected and repaired as needed.



The electrical insulation resistance of each circuit should be measured and recorded.



Major changes in insulation resistance or trace heater current should be resolved. In the event of an earth fault or over current interruption, the device shall not be reset until the cause of the trip has been investigated by qualified personnel.

Technical specifications

Model	SR-LENDCAP
Operating Voltage	120 V AC and 240 V AC
Ambient Temperature Range (Ta)	-40°F to +149°F (-40°C to +65°C)
Protection Grade	Type 4X; IP65
Indicator Circuit Voltage	9.8 V DC
Indicator Amperage	62mA Max.
Minimum Installation Temperature	-40°F (-40°C)
Maximum Conductor Size	14 AWG (2.5mm ²) multi-strand or solid
Hazardous Locations Ratings Marking*	Class I, Division 2, Groups A, B, C and D; T5 or T6 Class II, Division 2, Groups F, G; T5 or T6; Class III; T5 or T6;
Required Ground Fault Equipment Protection (GFEP)	30mA
Weight	415g (14 5/8 oz)

* For hazardous locations, WSR self-regulating cable MUST be installed with Warmup approved accessories for hazardous locations

Contact

Warmup is available 24/7/365 at (888) 927-6333
For quotes, layouts and specific technical information contact us at:

Warmup Inc

www.warmup.com
us@warmup.com
T: +1 (888) 927-6333

25 Francis J Clarke Cir,
Bethel, CT 06801

Warmup Canada

www.warmup.com
ca@warmup.com
T: 1+ (888) 592-7687

Please be advised Warmup Inc., provides these technical specifications and or instructions on a self help basis. We take every precaution to ensure they are accurate. Some of the products are sourced from manufacturers and we relay that information on to you. We do not have the technical specifications reviewed by an engineer and sometimes errors do happen. Our products are only reviewed with an ordinary level of care and when using said products in a situation that warrants additional care please be sure to conduct your own review. As such we strongly suggest before installing our products you have them reviewed by a professional engineer or qualified professional. We under no circumstances warrant our products for a particular use unless specifically agreed in writing.