

### PRODUCT CODE

PRO-A Aerial SnowOwl

### PRODUCT DESCRIPTION

The PRO-A Snow Sensor detects falling or blowing precipitation as snow, at temperatures below 38°F (3.3°C). The PRO-A provides the industry's most versatile and cost effective automatic snow melting sensor.

Reliability and sensitivity are key PRO-A features. The solid state design, combined with a rugged PVC housing ensure many years of trouble free service. Precision precipitation and temperature sensors assure snow detection accuracy.

Typical applications include controlling snow melting systems for sidewalks, doorways, stairs, loading docks, ramps for the physically challenged and parking garages.

Easy installation is another key PRO-A feature.

Low voltage operation, up to 2000' (609.6m) separation from the control panel, mast or roof mounting, and noncritical extension wiring are just a few of the features making this possible.

### ADVANTAGES

- Minimum snow melting costs
- No supervision required
- Simple installation

### SPECIFICATION

Area of Use	Gutters or Pavement (in conjunction with PRO-G-H or PRO-R)
Heater hold-on timer	None
Activation Temperature	38°F (3.37°C)
Circuit type	NEC Class 2
Supply voltage	24 VAC (Supplied by panel)
Output Signal	Voltage drop
Bus-wire type	3-wire jacketed cable
Lead Length	Up to 2,000' (609m) using 12 AWG 3-wire jacketed cable Up to 500' (152m) using 18 AWG 3-wire jacketed cable
Operating temperature	-40°F to 160°F (-40°C to 71°C)
Storage temperature	-50°F to 180°F (-45°C to 82°C)

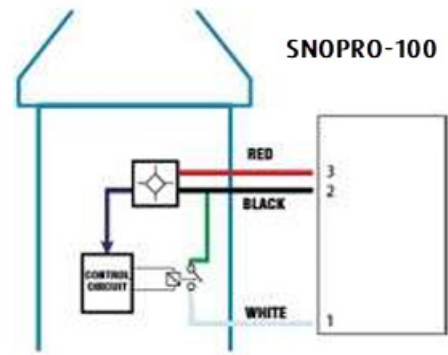



The world's **best-selling** electric floor heating brand™

# PRO-A AERIAL SNOW SENSOR SUBMITTAL SHEET WSC-2312

## WARRANTY & MAINTENANCE

When installed according to the installation manual, the PRO-A is covered with Warmup's 2-year manufacturer warranty.

## TECHNICAL SUPPORT

Warmup is available 24/7/365 at (888) 927-6333.

For quotes, layouts and specific technical information, contact us at:

### Warmup USA

25 Francis J Clarke Cir., Suite A, Danbury, CT 06810

(888) 927-6333

us@warmup.com

### Warmup CANADA

374 Wellington St W, Toronto, ON M5V 1E3

(905) 990-2075

ca@warmup.com

## RELATED PRODUCTS

- PRO-G-H Ground Sensor
- PRO-R Gutter Sensor
- SNOPRO-100W WiFi and SNOPRO-100

### WARMUP INC.

USA: us@warmup.com

Tel.: 1-888-927-6333

www.warmup.com

CANADA: ca@warmup.com

Tel.: 1-888-592-7687

www.warmup.ca



The world's **best-selling** electric floor heating brand™