

Bring warmth &
comfort to your
home with Warmup®

Warmup®

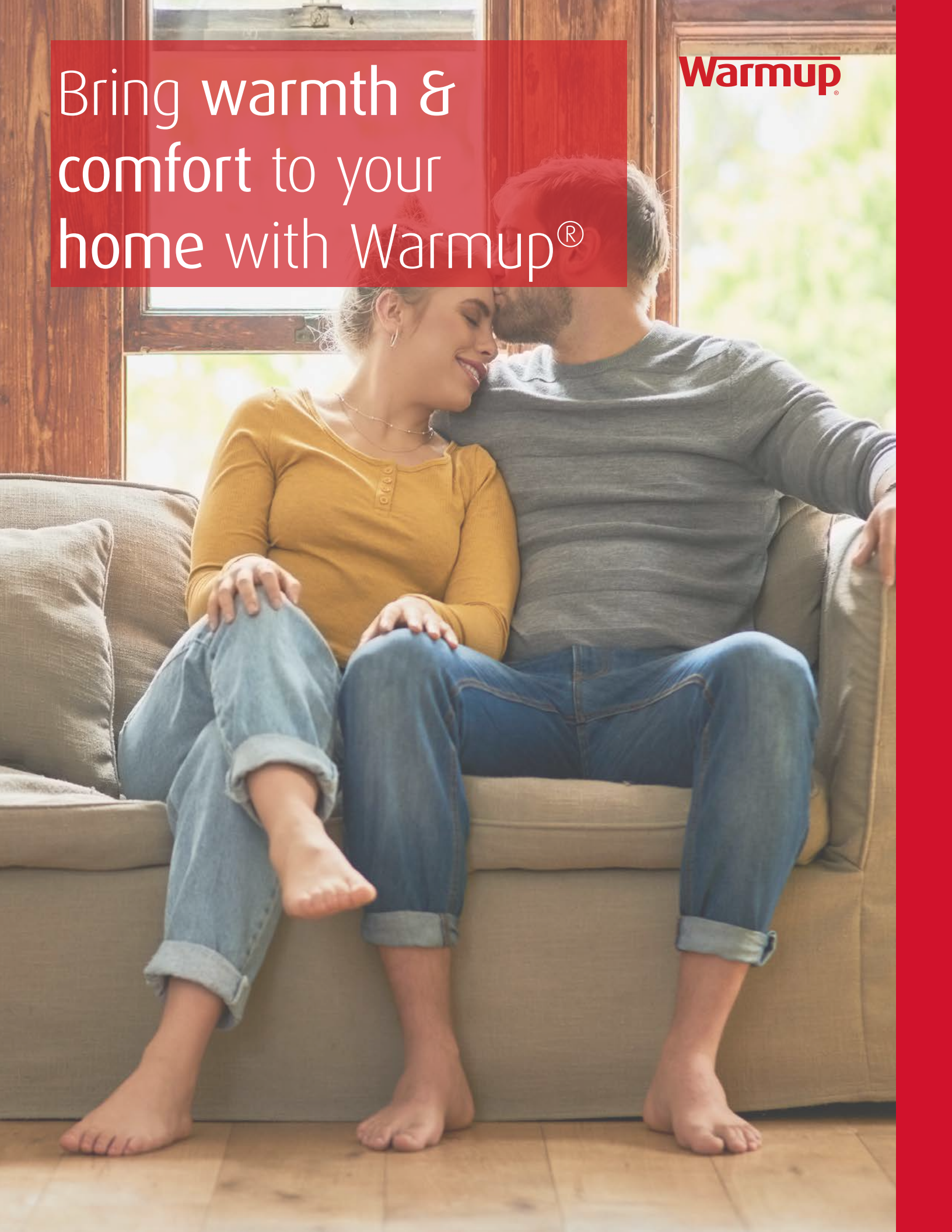

Here for you

From providing estimates to answering product questions and getting you the materials you need, the Warmup Customer Experience Team is there to help every step of the way.

Questions



Call or email us. We don't have a fancy answering service, but we have real friendly people. They'll answer your sales and technical questions or connect you with your local sales person right away!

In the USA: (888) 927-6333 / ussales@warmup.com or us@warmup.com

In Canada: (888) 592-7687 / ca@warmup.com

Online: www.warmupedia.warmup.com / www.youtube.com/user/WarmupInc

Quotes



You can submit a fax or email us with anything good enough to describe your project. From a set of blueprints to a few notes on a napkin, we've seen it all. Don't be shy, send it over.

We'll complete a detailed installation plan for you within 24 hours. Just let us know whether you want a quick price over the phone, or a detailed review of your project.

Orders



Email or fax us. We're never too busy to take your order. If it's your first time, we'll get you set-up same day and make sure your order is dispatched promptly. Please note that all orders need to be in writing.

FAX: (888) 927-4721

Policies, Simplified



Shipping is a standard \$25 + \$25 per large item (DCM-PRO membrane, WIU, WIB)

Payment is due in full prior to credit approval.

Returns are allowed within 30 days with no penalty. After 30 days, returns are subject to a 20% restocking fee.

For complete general terms please see page 3.

Warmup General Terms

PAYMENT TERMS

Orders placed prior to credit approval will be subject to full prepayment. Warmup standard payment terms are net 30 days from date of invoice. Special terms and conditions can be negotiated and discussed with your Key Account Manager. A credit application with signed business terms must be on file with Warmup. Please include a copy of your Resale Certificate.

REMIT PAYMENTS

In the USA:

Warmup, Inc
25 Francis J Clarke Circle, Suite A
Bethel, CT, 06801

In Canada:

Warmup, Inc
C/O TH1067
PO Box 4283
Postal Station A
Toronto, ON, M5W 5W6

Shipping and handling will be invoiced with the products purchased. All standard orders carry a flat \$25 freight charge and are shipped UPS Ground. Expedited shipments are invoiced 'at cost' based on Warmup's discounted rate. Oversized SKU's carry additional costs such as WIB insulation boards and DCM-PRO membrane boxes and rolls (\$25 each).

RETURNS

Returns, in resalable condition, are allowed within 30 days of purchase for a full refund. You must request an RGA from Warmup. Returns received without RGA cannot be refunded. After 30 days of purchase, or after expiration of the RGA, Warmup will only issue credit notes on future orders and apply a 20% re-stocking fee.

ORDERS MUST BE SUBMITTED IN WRITING

Fax: (888) 927-4721

In the USA: us@warmup.com

In Canada: ca@warmup.com

Orders placed before 1:00PM (EST) will be shipped same or next day, UPS. Orders placed after the deadline will be shipped promptly the following business day. All deliveries must be inspected for accuracy within 7 days of receipt. No claim can be accepted thereafter.

ONLINE POLICY

The Warmup brand is exclusive to established and approved brick & mortar resellers. The Warmup products cannot be sold online through third-party resellers such as Amazon or eBay. Warmup resellers may post product on their websites following the MAP policy. To obtain a copy and offer our products on your company website, please contact us@warmup.com.

For complete and up-to-date Warmup Inc. Terms and Conditions, visit warmup.com or warmup.ca.

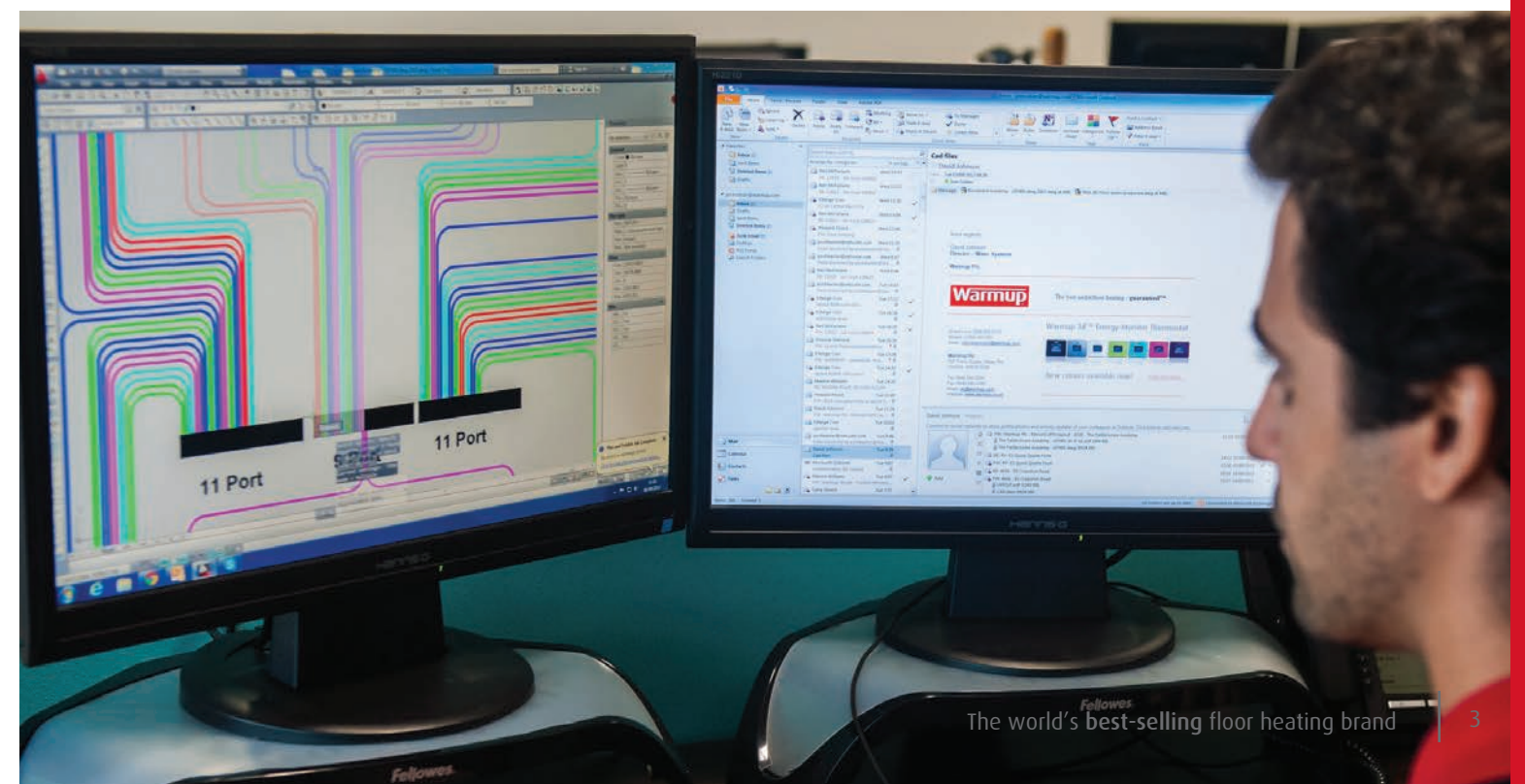

Sales Support

We want to support your sales team so that you can sell with confidence. We're here with the tools and training you need to succeed.

Shop our selection of showroom displays, samples & more on warmupedia.warmup.com



Warmup on hand is more in demand. Meet your customers needs with one of our towers designed to promote in-store stock.
Tower Display (left)
Stock Display (right)

Retail locations can now choose from our range of towel warmers to meet their showroom display needs. All towel warmer display orders will come complete with a wall mounted brochure holder and a ring of sample finishes.

See pages 32-34

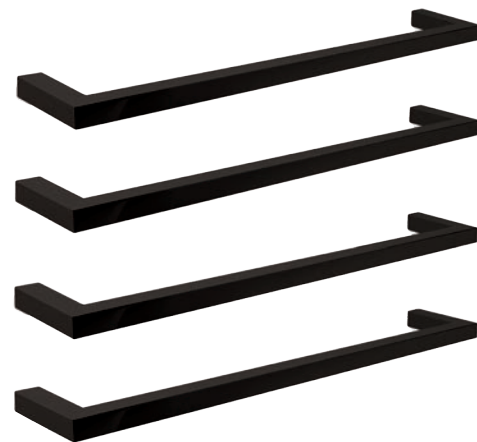

The DCM-PRO Counter Top Display features a removable DCM-PRO sample and brochure holder.
M-DCMPROCTD (2 per box)

Technical Support

Warmup is dedicated to helping you when you need it the most.

Did you know that we offer 24/7 Customer Support and a SafetyNet™ guarantee in case the cable gets damaged during the installation? Warmup also offers tool rental to find a potential break in the cable, and repair kits to fix damage.

These are some of the many ways Warmup aims to provide an exceptional customer experience, every step of the way.

Rent tools or buy them online, along with our repair kits or a Digital Multimeter (illustrated below) on warmupedia.warmup.com.



Digital Multimeter

Infrared thermal camera

TDR Meter

Megger (mega-ohmmeter)





















Warranties & Guarantees

Warmup provides a **Lifetime Warranty** on all its under tile floor heating products because not only do we maintain the highest standards in manufacturing, we are the only company with an EN422-2 Testing Facility that continuously tests, Quality-Controls and improves our range of heating solutions.

Despite the harsh environments in which they operate, Warmup is able to provide a 10-year warranty on all its outdoor heating cable solutions. This promise is well-beyond industry standards and is paired with the most practical and effective promise: Warmup's SafetyNet™ Guarantee.

The SafetyNet™ Guarantee offers all installers the ability to receive a free and immediate replacement for product damaged onsite, for any reason. Because 99% of issues happen during installation and not thereafter, Warmup wants to ensure that the system installed is free and clear of any defects or damage.

For detailed Warranty and SafetyNet™ terms, visit www.warmup.com/warranty

DCM Cable		
DCM Membrane		
DWS Cable		
DWM StickyMat		
FOIL		
WODH In-Slab		
SR Freeze Protection	 	
WSM & WSMM Snow Melting		
MD & TW Bathroom Collection		
Indoor Thermostats		
Outdoor Controls	  	
WRGH Cable De-Icing		

We carry multiple approvals on much of our range. For all our approvals, visit www.warmup.com



Warmup

Bring warmth & comfort to your home with Warmup® Floor Heating





Make it Radiant

WHY USE UNDERFLOOR HEATING?

Traditional furnace heating systems heat the air, which then warms up the people in the room. Radiant heating systems work by directly warming the people and objects in a room. This type of heating often feels like the warmth of the sun and because the heat is stored in your floor, it is actually very efficient to run.

“Radiant heating has a number of advantages. It is more efficient than baseboard heating and usually more efficient than forced-air heating because it eliminates duct losses. People with allergies often prefer radiant heat because it doesn’t distribute allergens like forced air systems can.” U.S. Department of Energy.

Energy Efficient - Electric systems are viewed as expensive, but electricity is 100% effective. You can heat a 100 sqft bathroom with about 600 watts, or the equivalent of a few lightbulbs.

Versatile - Install it in the bathroom, sunroom, or the whole house! Warmup heating systems deliver primary heating under any type of flooring.

Indoor Air Quality - Your furnace kicks on 9x an hour on average and replace the air in the room, circulating pet dandruff and other allergens into the air. None of that happens with heated floors. They are silent, invisible, and maintenance free.

Ease of Installation - Warmup® systems are easy to install and supported by a technical team 24/7. Let us connect you with an experienced installer for your project.

WHAT ARE THE WARMUP SOLUTIONS?

HEAT UNDER ANY TYPE OF FLOORING WITH A 4iE® THERMOSTAT



The 6iE® is a Smart thermostat that works with you to provide an optimal, cost-effective and energy-efficient heating system. For use with electric underfloor heating systems and electric baseboard heat, the 4iE does not require programming and uses Warmup’s latest technologies to ensure your home is always at the desired temperature, at the right time. See more on page 22.

USE UNDER TILE & STONE, LVT’S AND GLUED-DOWN WOOD FLOORS

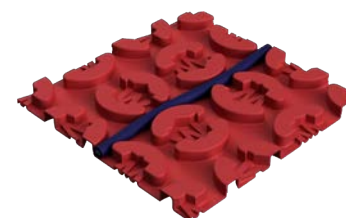

Warmup DCM-PRO system comprises a cable designed to fit the Warmup DCM-PRO Membrane. The cable can be spaced to customize heat output and coverage. Use DCM-PRO under tile, stone, LVT and over most subfloors. See more starting on page 6.



The Heating Mat system consists of a thin 1/8” wire evenly spaced and taped to a fiberglass mesh with pressure-sensitive adhesive. The adhesive securely binds the mats to the floor. The Sticky Mat System is ideal for installations in regularly shaped areas, where the 20” or 3’ wide mats can be quickly rolled out across the floor. It is also compatible with all floor coverings once embedded in leveler, thin-set, or mortar. See more on starting on page 16.

USE UNDER CARPET OR FLOATING ENGINEERED



The Warmup FOIL system is an electric mat for floating floors that requires no mortar. It is designed to be installed between underlay and the finished flooring. All tested carpet pads are sufficient underlay. For laminate and wood installations, Warmup recommends the use of WIU insulation to provide better heat outputs and faster heat-up times. See more on starting on page 20.

USE IN-SLAB



The Warmup In-Slab cable System is designed for use within a concrete slab. The cable spacing can be altered between 3”-5” to fit the heating requirements and the thickness of the slab. Warmup WODH cables provide 20W per sqft or up to 70 BTUs per hour and easily replace water-based applications. With an electric system there is no boiler, no pump, no manifolds and no maintenance required. It is the ideal solution in basements and room additions. See more on page 15.

PLANNING YOUR PROJECT

RELY ON US

You can email us (ussales@warmup.com) with anything good enough to describe your project. From a set of blueprints to a few notes on a napkin, we've seen it all. Don't be shy, send it over. We'll complete a detailed installation plan for you within 24 hours.

CALCULATE IN A FEW EASY STEPS

Warmup heating cables are not installed wall-to-wall or under any fixtures that lay flush to the floor. To calculate what size system you will need, measure your room and deduct any fixtures (i.e. toilets, vanities, washers, dryers, cabinets).

Using the heated square footage you can proceed to the product pages and follow the steps to assemble an order for your project.

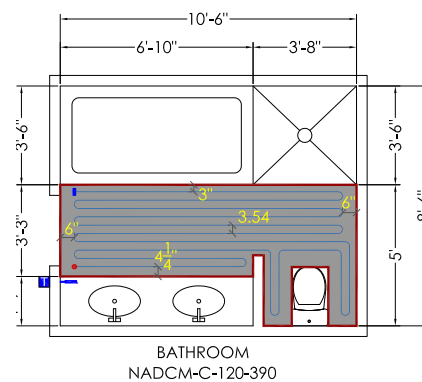

SUBFLOOR TYPES AND INSULATION

You can install heated floors over plywood, cement boards or concrete slabs. Different methods will apply, but the main consideration should be heat loss. Typically, this is not an issue over plywood as it acts as an insulator. However, when installing over slabs or uninsulated crawl spaces, the heat from your system may be wasted downwards rather than heating the room. Consider the insulation panels from Warmup available on p. 20 to reduce heat loss and improve your system's efficiency.

CONTROLS & ELECTRICAL PROVISIONS

For projects requiring up to 120 sqft of heating, 120-volt system power should be sufficient. In smaller rooms, you may be able to utilize the power of an existing circuit, but beyond 60 sqft, check with an electrician whether you need a dedicated service.

For projects beyond 120 sqft, we recommend designing a 240 volt system. Both voltages are equally efficient, but 240 volt wiring allows for more amperage and therefore square footage on a single thermostat.

Warmup thermostats can switch up to 15 Amps of power, or about 300 sqft at 240V.

For areas larger than that, add a RL-240 relay (Page 9) which expands your system 500 sqft at a time. Warmup recommends "zoning" larger installations. This means that for every space used at different times or different temperatures, plan to have a thermostat. For example, you can put the Kitchen + living + dining on one circuit, or the Master Bed + Bath on another.

And yes, you can even warm a shower floor!

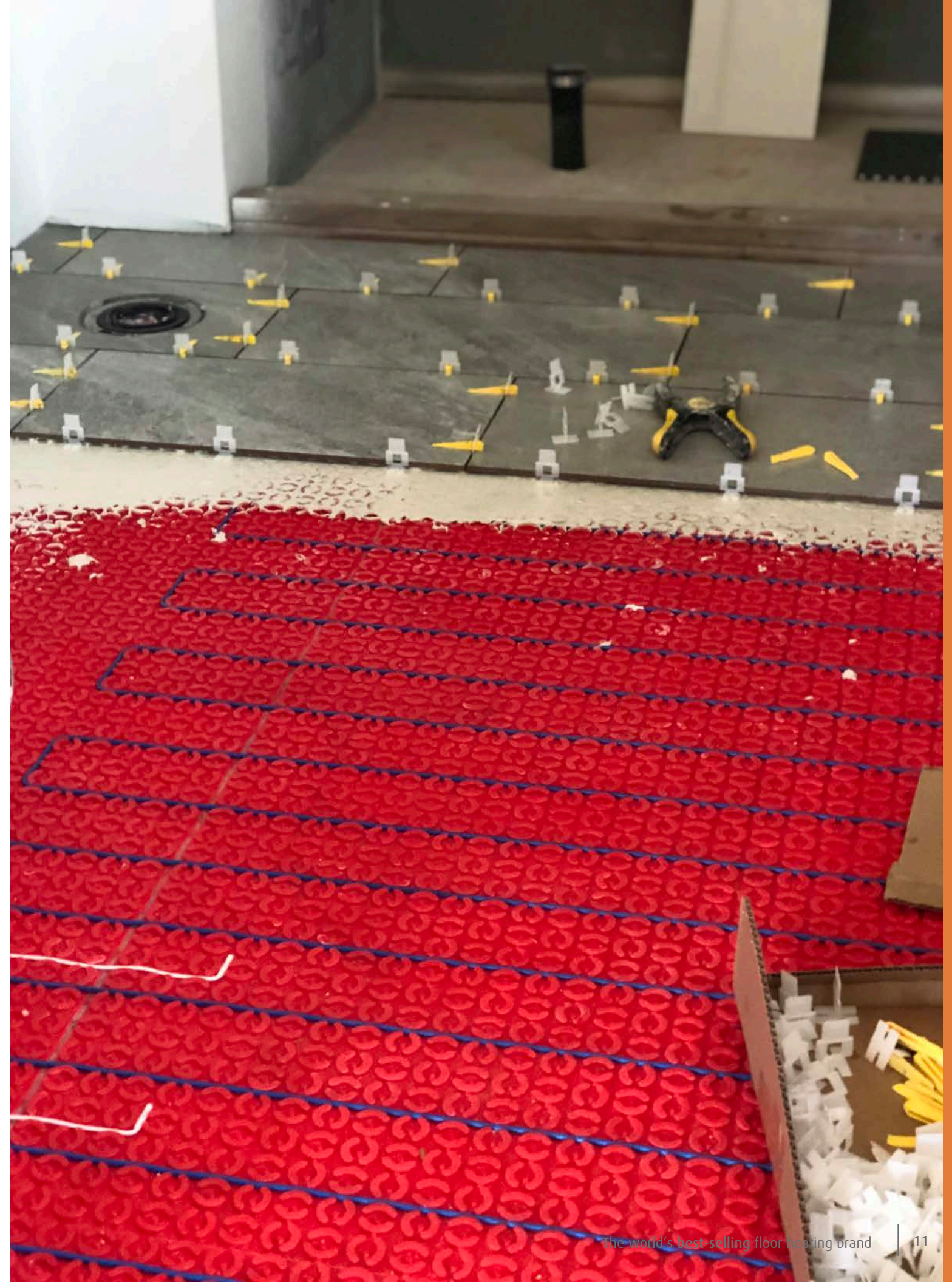

DCM-PRO Cable

Warmup DCM-PRO Cable is designed to fit the Warmup DCM-PRO Membrane.

For better results, pair with the Warmup 4iE® Smart thermostat for lowest consumption cost when installed with 1/4" Warmup Ultralight™ 3-in-1 insulation boards.

The cable can be spaced at various intervals for the highest flexibility in heat outputs, from Comfort Heating to Primary Heating.

Quote in 5 Easy Steps:

1. Cable
2. Membrane OR Fixing Strips
3. Accessories
4. Thermostat
5. Optional Insulation

Thickness	3/16" (4.5mm - +/- 0.2mm)
Output	Varies with spacing from 11w/sqft to 20w/sqft
Construction	Multi-stranded, dual wire
Inner insulation	ETFE
Outer jacket	PVC
Ground braid	85% min copper
Cold lead	10ft (3m) long, 2 core braided

The DCM-PRO system is warranted for life when comprised of a Warmup thermostat, the DCM-PRO Membrane and the DCM-PRO Cable. For full warranty details, see www.warmup.com/about/best-warranties

The **only UL-Approved** membrane system in North America

Tiled floor

Subfloor

DCM-PRO'S ANTI-FRACTURE LAYER

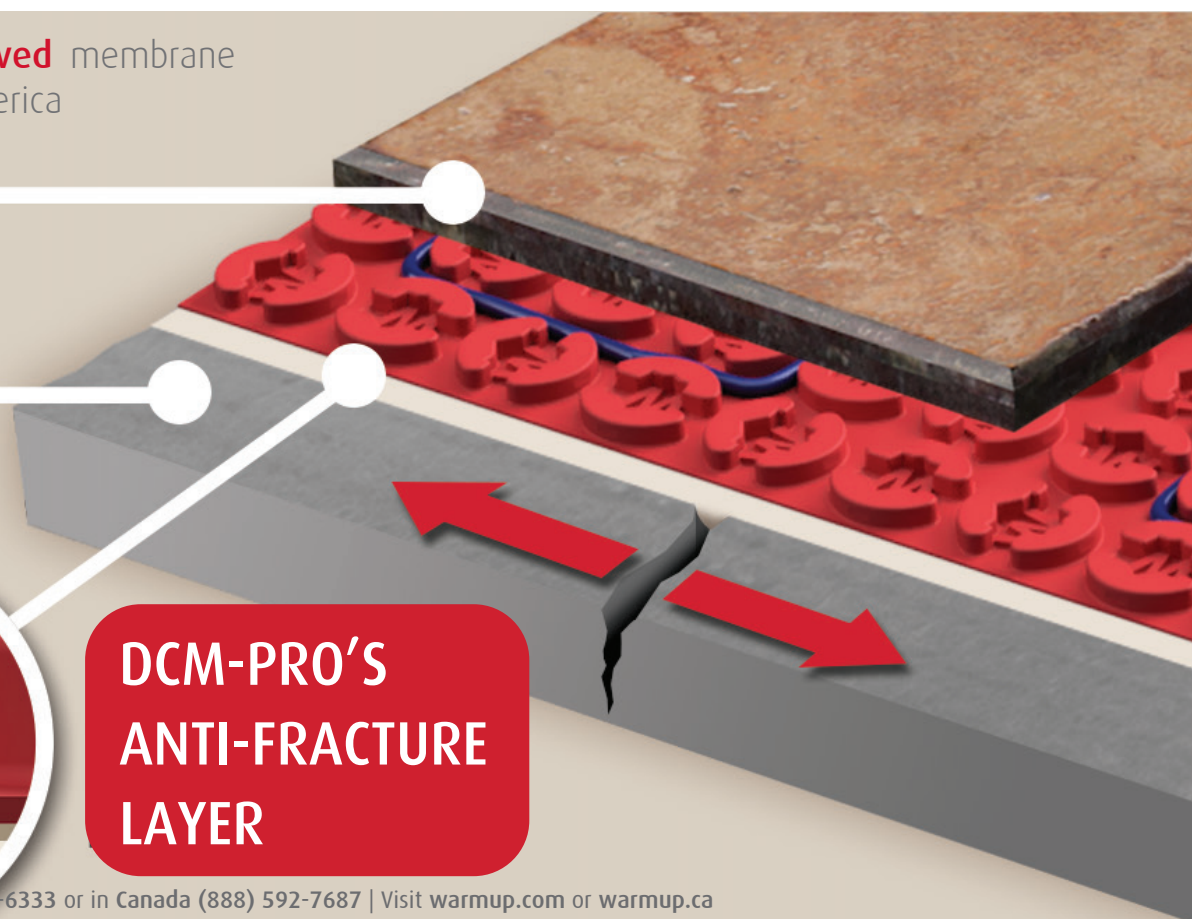

1.

	PRODUCT CODE	Cable length (ft)	Amps	Resistance (Ω)	Square Foot Coverage with Membrane				Square Foot Coverage Loose Lay		Canada	USA
					2-3 pegs	3 pegs	3-4 pegs	4 pegs	3"	4"		
120 Volt	DCM-120-65	16.7	0.5	221.5	4	5	6	7	4	6	\$175.50	\$140.00
	DCM-120-130	33.1	1.1	110.8	8	10	12	13	8	11	\$202.00	\$161.50
	DCM-120-195	49.9	1.6	73.8	13	15	18	20	12	17	\$254.50	\$203.50
	DCM-120-260	66.3	2.2	55.4	17	20	23	27	17	22	\$280.50	\$224.00
	DCM-120-325	83.0	2.7	44.3	21	25	29	33	21	28	\$321.50	\$257.00
	DCM-120-390	99.4	3.3	36.9	25	30	35	40	25	33	\$348.50	\$278.00
	DCM-120-525	132.9	4.4	27.4	33	40	47	53	33	44	\$422.50	\$337.50
	DCM-120-655	166.0	5.5	22.0	42	50	58	67	42	55	\$471.50	\$376.50
	DCM-120-785	199.1	6.5	18.3	50	60	70	80	50	66	\$520.00	\$415.50
	DCM-120-920	232.3	7.7	15.6	58	70	82	93	58	77	\$559.50	\$446.50
	DCM-120-1050	265.4	8.8	13.7	67	80	93	107	66	88	\$616.50	\$493.00
	DCM-120-1180	298.6	9.8	12.2	75	90	105	120	75	100	\$681.50	\$544.50
	DCM-120-1315	331.7	11.0	11.0	83	100	117	133	83	111	\$738.50	\$590.50
	DCM-120-1445	364.8	12.0	10.0	91	110	128	147	91	122	\$793.50	\$634.00
DCM-120-1575	398.0	13.1	9.1	100	120	140	160	99	133	\$805.50	\$625.50	
240 Volt	DCM-240-195	50.0	0.8	296.0	13	15	18	20	12	17	\$250.00	\$203.50
	DCM-240-325	83.0	1.4	177.2	21	25	29	33	21	38	\$340.20	\$272.00
	DCM-240-390	99.4	1.6	147.7	25	30	35	40	25	33	\$346.50	\$277.00
	DCM-240-525	132.9	2.2	109.7	33	40	47	53	33	44	\$418.95	\$335.00
	DCM-240-655	166.0	2.8	87.9	42	50	58	67	42	55	\$455.70	\$364.00
	DCM-240-785	199.1	3.3	73.4	50	60	70	80	50	66	\$512.40	\$410.00
	DCM-240-920	232.3	3.9	62.6	58	70	82	93	58	77	\$563.85	\$451.00
	DCM-240-1050	265.4	4.5	54.9	67	80	93	107	66	88	\$604.80	\$483.50
	DCM-240-1180	298.6	5.0	48.8	75	90	105	120	75	100	\$658.32	\$526.50
	DCM-240-1310	331.7	5.6	44.0	83	100	117	133	83	111	\$696.80	\$558.00
	DCM-240-1640	414.7	7.0	35.1	104	125	146	167	104	138	\$790.00	\$632.00
	DCM-240-1970	497.7	8.4	29.2	125	150	175	200	124	166	\$940.50	\$752.00
	DCM-240-2300	580.7	9.8	25.0	146	175	204	233	145	194	\$1,089.00	\$871.00
	DCM-240-2630	663.4	11.2	21.9	166	200	233	266	166	221	\$1,130.00	\$903.50
	DCM-240-2955	746.4	12.6	19.5	187	224	262	300	187	249	\$1,209.00	\$967.50
	DCM-240-3240	829.4	13.5	17.8	208	249	292	333	207	276	1,330.00	\$1,063.50

*for 208V figures, see product specification sheet, which can be found on warmup.com or warmup.ca

2. APPLICATION - MEMBRANE OR FIXING STRIPS

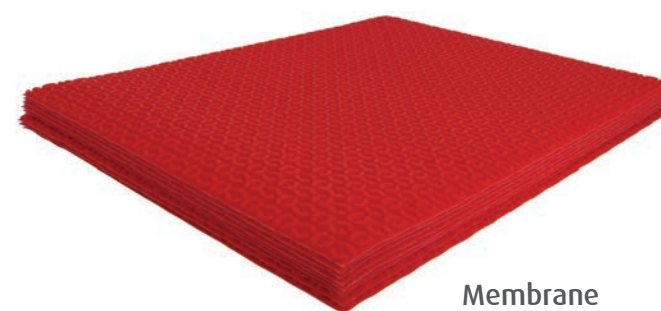

DCM-PRO Uncoupling Membrane

Peel-and-Stick or Fleece-Backed

The TCNA-tested DCM-PRO anti-fracture Membrane is available in peel-and-stick or fleece-backed and can be installed on wood and cement subfloors using any tile adhesive. The patented DCM-PRO design allows

for more cable to adhesive contact, ultimately distributing heat more evenly. There is no waiting required after installation so you can begin laying the flooring immediately.

Application

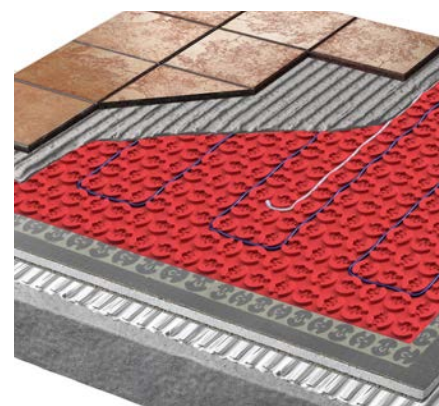

Peel-and-Stick

Installs in minutes with self-adhesive backing.

- Ideal for installation over plywood, concrete, or WIB
- Best for remodels and multi-units for fast installation
- Tile immediately
- 40% savings on labor and material
- Doesn't roll back: no memory
- Increased thinset-to-cable contact for more efficient heating

NO THINSET REQUIRED BELOW

Code	Description	Dimensions of each sheet/roll	Canada	USA
DCM-PSW-80	Box of 10 Peel-and-Stick sheets, covering 81.6sqft in total.	3'3" x 2'7"	\$293.00	\$234.00
DCM-PSW-150	Roll of Peel-and-Stick membrane, covering 150 sqft in total.	3'3" x 47'2"	\$471.50	\$377.00

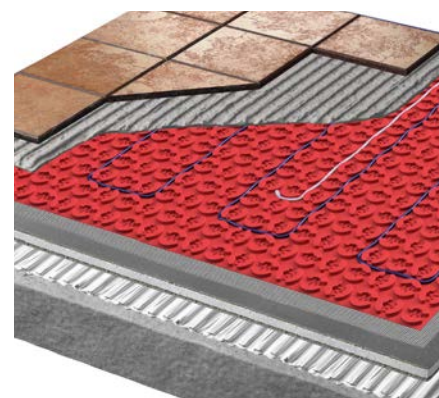

Fleece-Backed

Use with any tile adhesive above and below

- Ideal for installation over rough and uneven subfloors (OSB)
- Tile in 1 hour
- Apply and cover with modified adhesives
- Compatible with Self-Levelers
- Increased thinset-to-cable contact for more efficient heating

Code	Description	Dimensions of each sheet/roll	Canada	USA
DCM-MW-80	Box of 10 Fleece-backed sheets, covering 81.6sqft in total.	3'3" x 2'7"	\$262.00	\$209.00
DCM-MW-150	Roll of Fleece-backed membrane, covering 150 sqft in total.	3'3" x 47'2"	\$459.00	\$367.00

3.

Code	Accessories	Canada	USA
ACC-DGMTR	The Alligator Tester - Digital Multimeter.	\$25.00	\$20.00
DCM-SP-10K	Additional Floor Sensor for the 4iE®.	\$26.00	\$21.00
RL-240V25A	General purpose 25A/240V relay used to expand the switching capability of the Warmup thermostats. Mounts in single gang box.	\$106.00	\$85.00
DCM-FB-82	Metal fixing band. 82' long spool.	\$133.00	\$108.00
ACC-PLTL	Heavy Duty Plastic Trowel 11" x 5.5" with 1/4" U-notch design.	\$15.00	\$14.97
RK-INDOOR	Indoor heating cable repair kit.	\$13.00	\$10.00
RK-ENDCAP	Indoor heating cable end cap repair kit.	\$13.00	\$10.00
RK-JOINT	Indoor heating cable factory joint repair kit.	\$13.00	\$10.00
ACC-00WATCHDOG	The Watch Dog Tester - Sounds an alarm when connected to a broken heating cable.	\$25.00	\$20.00

Code	Waterproofing Accessories	Canada	USA
DCM-WP-ROLL	Waterproofing for DCM-PRO. Includes a 35ft roll of tape.	\$46.00	\$34.50
DCM-WP-IC	Waterproofing for DCM-PRO. Includes 2 inside corners	\$16.00	\$12.00
DCM-WP-OC	Waterproofing for DCM-PRO. Includes 2 outside corners	\$16.00	\$12.00

4.

Code	Thermostat	Canada	USA
6iE-04-CW-LC	Warmup's most popular thermostat, the white WiFi 6iE®	\$299.00	\$279.00

5.

Code	Optional Insulation	Canada	USA
WCI-01	Single 4'x2' Ultralight sheet with 3-in-1 capabilities: insulating, heat spreading, and decoupling.	\$38.00	\$29.28

The Warmup Advantage

Warmup's Membrane design provides better contact with the thinset or leveler. This allows for the heat to spread faster and more evenly through the floor. Other membrane restrict cable-to-thinset contact and cause overheating which reduces the cable lifespan. Additional features include:

- Speed and flexibility of installation at 2-3-4 peg spacing
- Primary Heating outputs
- Rated Heavy Commercial (ASTM C627)
- Anti-fracture protection (ANSI 118.12)
- Even floor temperature with better cable-to-thinset contact
- Suitable for every floor covering and ready to tile
- Waterproofing capability with DCM-WP-KIT

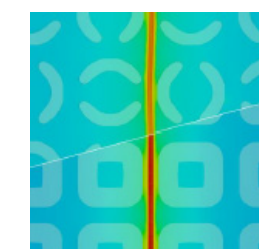

Temperature distribution of DCM-PRO (Top) vs. generic product (Bottom), through both the heated layer (Left) and the floor surface (Right)

The ONLY UL-APPROVED membrane heating system

The world's best-selling floor heating brand

DCM-PRO Project Examples

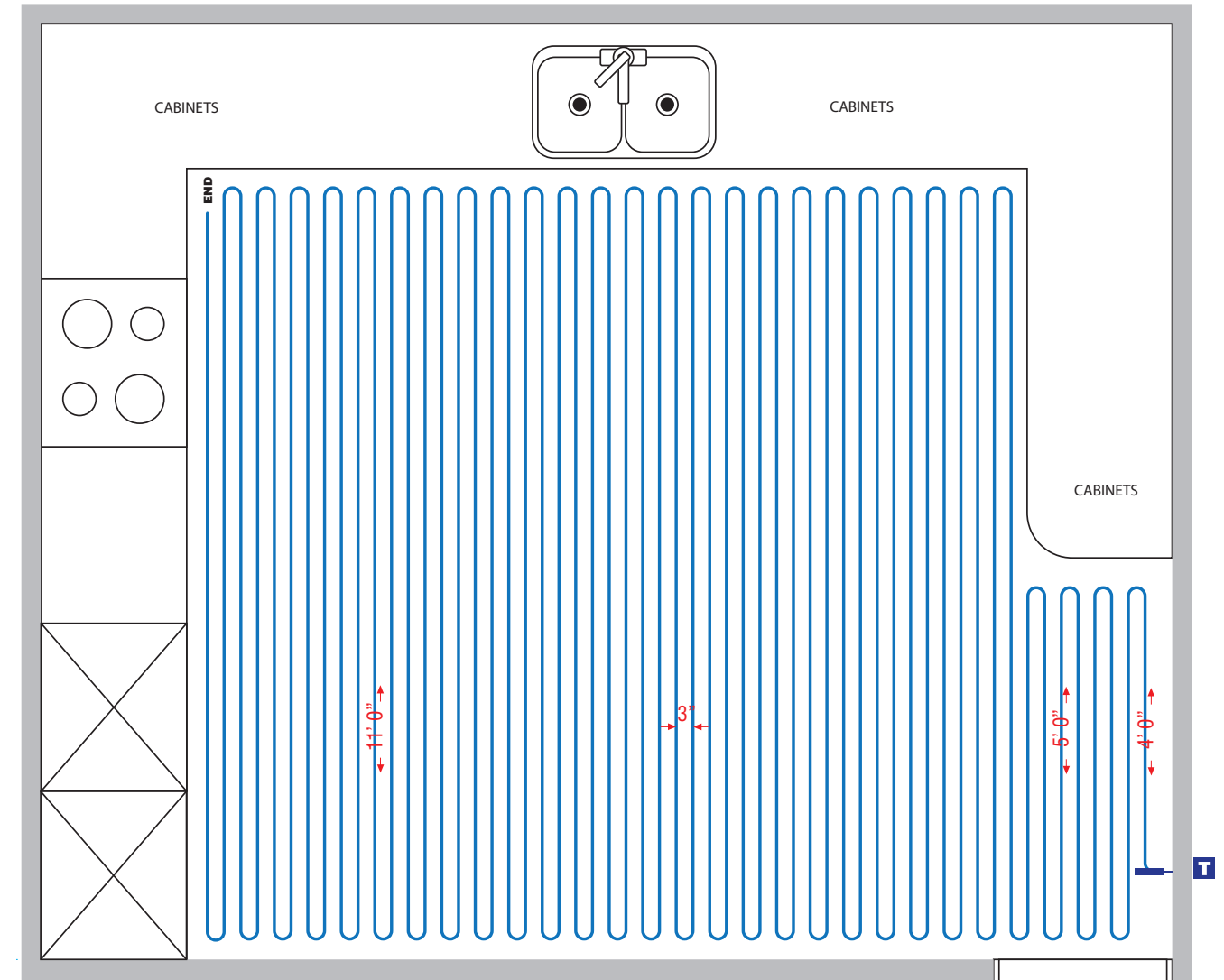
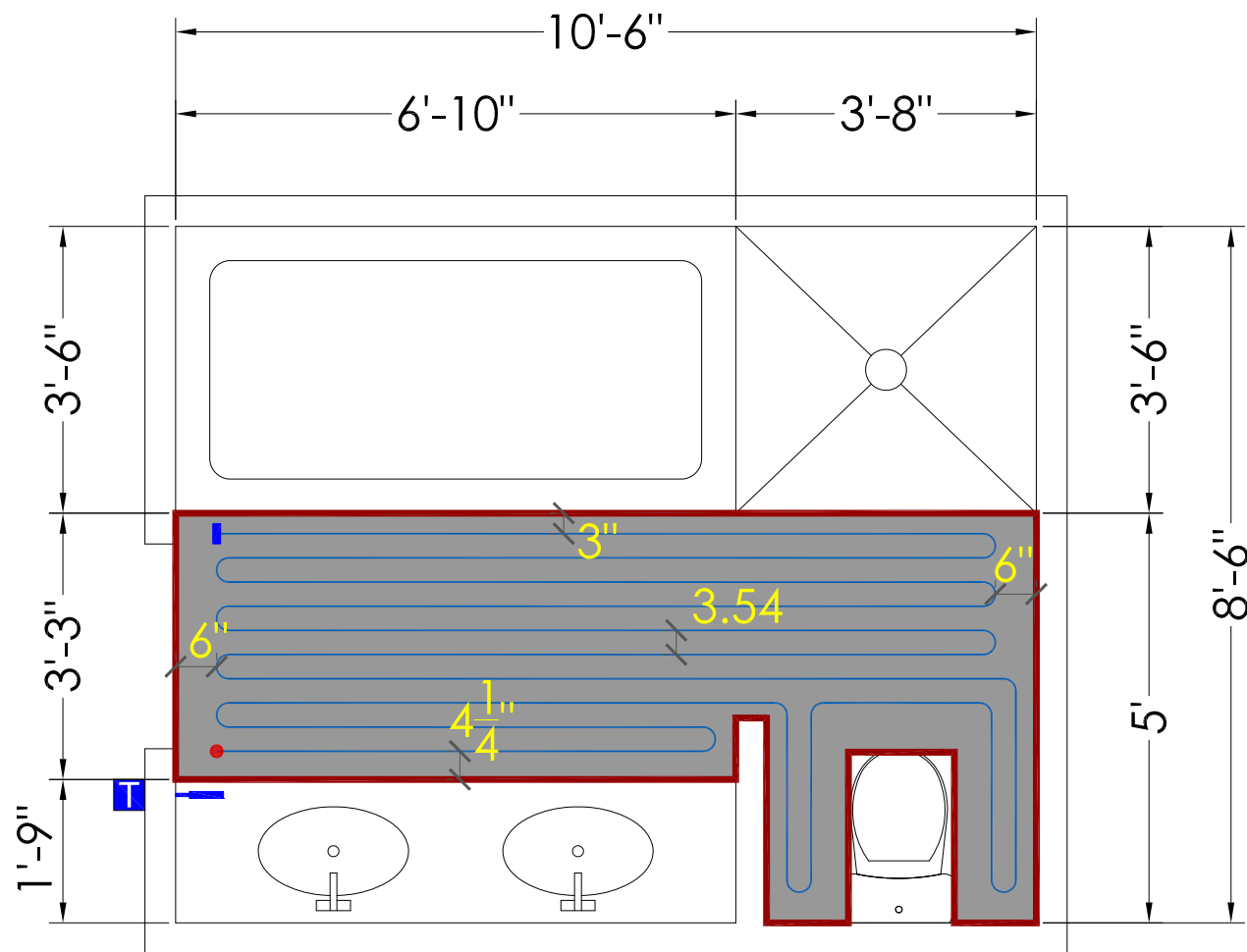

Size 89 sq. ft.		Price \$767.74		Type DCM-PRO											
Total Room Area	89 sq. ft.	<table border="1"> <thead> <tr> <th colspan="2">Specifications</th> </tr> </thead> <tbody> <tr> <td>Voltage</td> <td>120</td> </tr> <tr> <td>Amps</td> <td>3.30</td> </tr> <tr> <td>Monthly Cost to Run</td> <td>\$5.69</td> </tr> <tr> <td>Total BTU Equivalent</td> <td>1,330</td> </tr> </tbody> </table>		Specifications		Voltage	120	Amps	3.30	Monthly Cost to Run	\$5.69	Total BTU Equivalent	1,330		
Specifications															
Voltage	120														
Amps	3.30														
Monthly Cost to Run	\$5.69														
Total BTU Equivalent	1,330														
Surface to be Heated	35 sq. ft.														
Heating System	DCM-C-120-390	\$278.00													
Membrane	DCM-MW-80	\$209.00													
Thermostat	6iE-04-CW-LC	\$279.00													
Subtotal		\$766.00													

Size 237 sq. ft.		Price \$1,383.55		Type DCM-PRO											
Total Room Area	237 sq. ft.	<table border="1"> <thead> <tr> <th colspan="2">Specifications</th> </tr> </thead> <tbody> <tr> <td>Voltage</td> <td>240</td> </tr> <tr> <td>Amps</td> <td>8.21</td> </tr> <tr> <td>Monthly Cost to Run</td> <td>\$18.76</td> </tr> <tr> <td>Total BTU Equivalent</td> <td>6,723</td> </tr> </tbody> </table>		Specifications		Voltage	240	Amps	8.21	Monthly Cost to Run	\$18.76	Total BTU Equivalent	6,723		
Specifications															
Voltage	240														
Amps	8.21														
Monthly Cost to Run	\$18.76														
Total BTU Equivalent	6,723														
Surface to be Heated	150 sq. ft.														
Heating System	DCM-C-240-1970	\$752.00													
Membrane	DCM-PSW-150	\$377.00													
Thermostat	6iE-04-CW-LC	\$279.00													
Subtotal		\$1,408.00													

Waterproofing Kit

Recommended in wet areas such as bathrooms and showers

Having your bathroom waterproofed is one of the most important aspects of a home improvement project. That's because waterproofing not only protects structures against damage but also eliminates possible health concerns that can come from mold growth.



Warmup's 3-ply waterproof membrane protects floors and walls under thin-set tile installations from substrate cracks and moisture migration. It is comprised of 2 outer polypropylene layers and one inner polyethylene waterproofing membrane and exceeds testing requirements per ASTM 118.10. The kit includes a 35ft roll of 5"-wide membrane, along with 2 outer corners and 6 inside corners to complete waterproofing in most common bathrooms under 100 sqft.

Code	Waterproofing Accessories	Canada	USA
DCM-WP-B35	Waterproofing for DCM-PRO. Includes a 35ft roll of tape.	\$46.00	\$34.50
DCM-WP-IC	Waterproofing for DCM-PRO. Includes 2 inside corners	\$16.00	\$12.00
DCM-WP-OC	Waterproofing for DCM-PRO. Includes 2 outside corners.	\$16.00	\$12.00

DIMENSIONS

Roll	35' x 5"
Inside corner (2/kit)	115mm * 115mm
Outside corner (2/kit)	105mm * 105mm

Warmup's waterproof membrane is recommended in wet areas such as bathrooms and showers and is designed to be used in conjunction with the DCM series of Warmup membranes and heating systems (DCM-PRO).

- Apply on wood and cementitious substrates prepared for tile floors.
- Suitable for bathrooms, kitchens, showers and wet rooms in residential and commercial environments.
- Suitable for exterior applications on balconies and terraces.
- Can meet requirements of high moisture stress classifications (swimming pools) with appropriate sealants.

INSTALLATION

Apply the membrane with modified thin-set onto subfloor. As needed, mark areas where membrane will join on the floor in order to tape all seams and wall connections. Tape all wall surrounds by bending the tape at midpoint. Use corner pieces where suitable. Apply DCM-PRO membrane with thin-set ensuring that all seams are situated over waterproofing tape. Press down with lightweight roller, or manually with flat rubber trowel.

TECHNICAL SPECIFICATIONS

Temperature resistance	-22F/-30C to +194F/90C
Thickness	0.5 mm
Weight	.2 lbs/sqft, 307 grams/meter
Bonding Strength	0.2N/mm ²
Fire Classification	B2

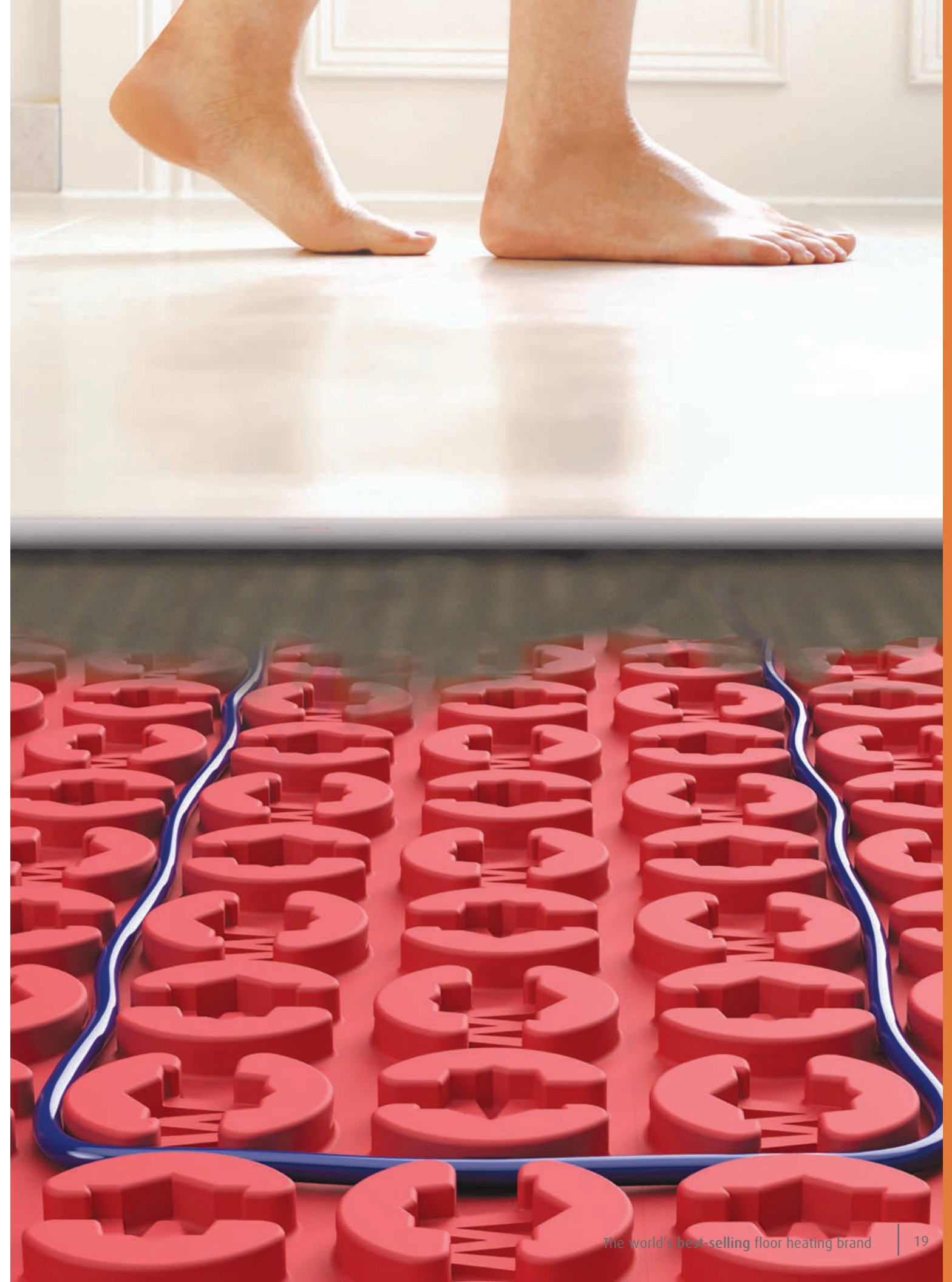

DCM-PRO Loose Cable System for Wood Floors

Use under nailed hardwood floors

Warmup loose cable for hardwood has been tested by many wood suppliers and is the ideal solution for radiant heating under solid wood floors. Installed at 3" to 4" spacing between sleepers about 10" to 16" on center, it allows for a nailing surface to protect the cable from damage. Filling the gaps between sleepers with thinset or drypack creates the heat mass

necessary to provide gradual and safe heating throughout the hardwood floors.

Electric floor heating systems do not affect moisture and will not impact your wood, unlike hydronic systems. It does not leak or freeze and is a tried and true solution in kitchens, basements, dining rooms and more.



DID YOU KNOW?

Warmup's 4iE thermostat blocks floor temps under wood at 81F automatically in order to comply with Wood Manufacturer warranties

SEE PAGE 7

Quote with cable at 3" loose lay spacing with DCM-FB-82 fixing band.

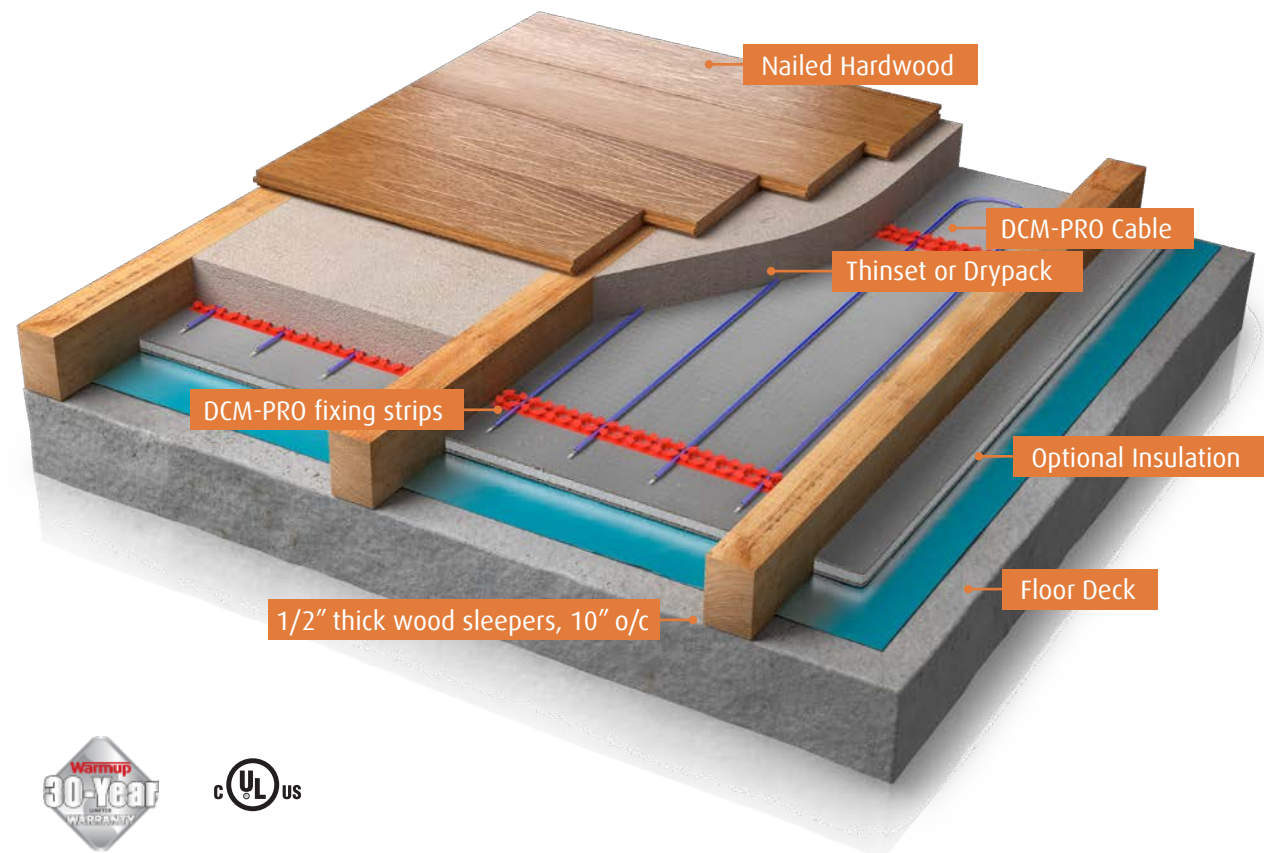

WODH In-slab cable Cable System for Slab Pours up to 6"

The Warmup In-Slab cable System is designed for use within a concrete slab. The cable spacing can be altered to fit the heating requirements and the thickness of the slab. Warmup WODH cables provide 20W per sqft or up to 70 BTUs per hour and easily

replace water-based applications. With an electric system there is no boiler, no pump, no manifolds and no maintenance required. It is the ideal solution for builders and remodelers in basements and room additions.

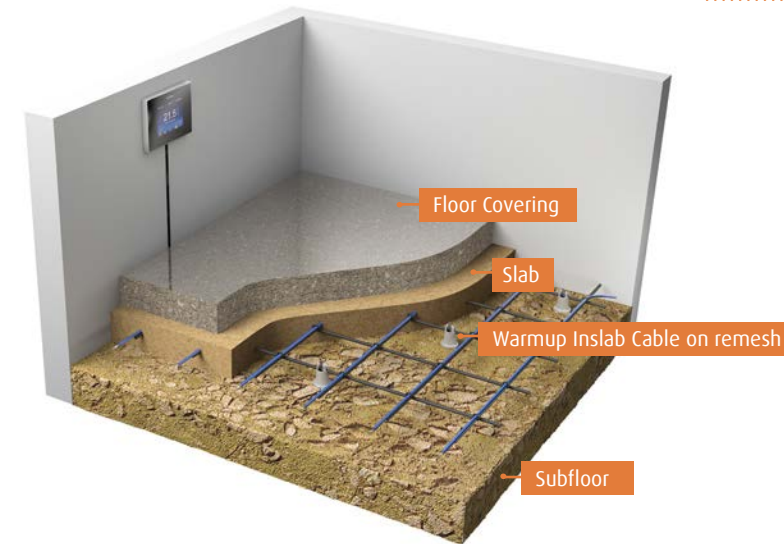

Quote in 3 Easy Steps:

1. Cable
2. Accessories
3. Thermostat



1.	Cable length	Code	3"	4"	5"	Wattage	Amps	Resistance (Ω)	Canada	USA
	93	WODH-240/500	24	30	39	500	2.1	114.30	\$354.50	\$283.00
	176	WODH-240/950	44	59	74	950	4.0	60.00	\$540.00	\$431.00
	250	WODH-240/1300	62	84	104	1300	5.4	44.40	\$622.50	\$497.00
	315	WODH-240/1700	76	104	130	1700	7.1	33.80	\$786.00	\$629.00
	437	WODH-240/2400	105	146	182	2400	10.0	24.00	\$1,055.00	\$842.50
	625	WODH-240/3400	155	210	260	3400	14.2	16.90	\$1,262.00	\$1,009.50

2.	Code	Accessories	Canada	USA
	ACC-DGMTR	The Alligator Tester Digital Multimeter.	\$25.00	\$20.00
	DCM-SP-10K	Additional Floor Sensor for the 4iE®	\$26.00	\$21.00
	RL-240V25A	General purpose 25A/240V relay used to expand the switching capability of the Warmup thermostats. Mounts in single gang box.	\$106.00	\$85.00
	DCM-FB-82	Metal fixing strips to fix the heating cable - 82 ft long.	\$133.00	\$108.00
	SR-ZT-100	Bag of 100 Heavy Duty Zip Ties. 7" long. For use with WSM, WODH and SR cable series. 50lbs load bearing capacity.	\$25.00	\$20.00

3.	Code	Thermostat	Canada	USA
	6iE-04-CW-LC	Warmup's WiFi white 6iE®	\$299.00	\$279.00

StickyMat™

Use under tile, stone & LVT

The Warmup StickyMat is designed for use within an adhesive layer under tiles or within a levelling compound under other floor finishes.

The fixed spacing and self-adhesive mat makes installation of regularly shaped rooms quick and easy, whilst ensuring precision is maintained.



Quote in 4 Easy Steps:

1. Heating Mat
2. Accessories
3. Thermostat
4. Optional Insulation

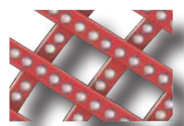
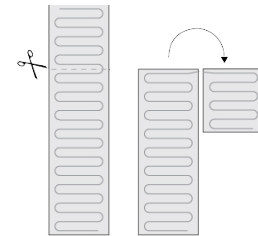

Close-up of the pressure-sensitive adhesive

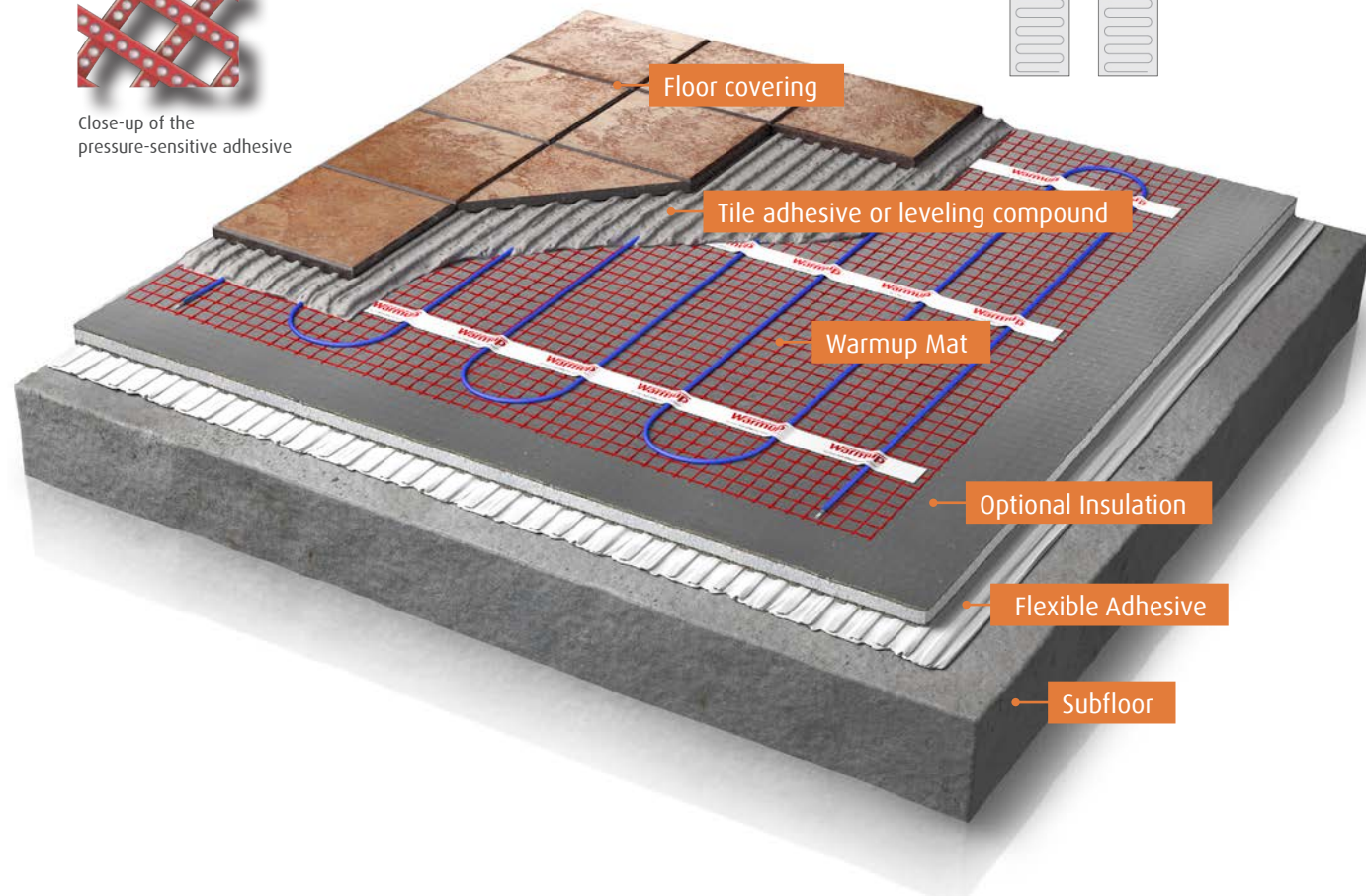

1. Area (sqft)	Code	Mat Length (ft) (20" wide)	Wattage	Amps	Resistance (Ω)	Canada	USA
10	DWM-120-140	6'	140	1.16	102.8	\$267.00	\$217.50
15	DWM-120-210	9'	210	1.75	68.5	\$338.00	\$275.00
20	DWM-120-280	12'	280	2.33	51.4	\$379.50	\$309.00
25	DWM-120-350	15'	350	2.91	41.2	\$431.00	\$351.00
30	DWM-120-420	18'	420	3.49	34.3	\$479.50	\$390.50
40	DWM-120-560	24'	560	4.66	25.7	\$595.50	\$485.50
50	DWM-120-700	30'	700	5.82	20.6	\$692.00	\$563.50
60	DWM-120-840	37'	840	7.01	17.1	\$805.00	\$655.00
75	DWM-120-1050	46'	1050	8.75	13.7	\$975.00	\$793.50
90	DWM-120-1260	55'	1260	10.52	11.4	\$1,130.00	\$920.00
110	DWM-120-1540	67'	1540	12.76	9.4	\$1,328.00	\$1,081.50
120	DWM-120-1620	73'	1620	13.48	8.9	\$1,427.50	\$1,162.50
25	DWM-240-350	15'	350	1.45	164.6	\$430.85	\$351.00
40	DWM-240-560	24'	560	2.33	102.9	\$595.39	\$485.50
50	DWM-240-700	30'	700	2.91	82.3	\$691.90	\$563.50
75	DWM-240-1050	46'	1050	4.37	54.9	\$974.05	\$805.00
90	DWM-240-1260	55'	1260	5.25	45.7	\$1,129.70	\$920.00
110	DWM-240-1540	67'	1540	6.41	37.4	\$1,355.42	\$1,081.50
150	DWM-240-2100	91'	2100	8.75	27.4	\$1,713.16	\$1,395.50
180	DWM-240-2520	110'	2520	10.48	22.9	\$1,979.45	\$1,612.00
220	DWM-240-3080	134'	3080	12.83	18.7	\$2,331.15	\$1,898.00
240	DWM-240-3240	146'	3240	13.48	17.8	\$2,452.69	\$1,997.00
9	DWM-09-120	3 x 3	126	1.05	114.3	\$249.00	\$198.50
15	DWM-15-120	3 x 5	210	1.75	68.5	\$325.00	\$264.50
18	DWM-18-120	3 x 6	252	2.10	57.1	\$367.00	\$298.50
24	DWM-24-120	3 x 8	336	2.80	42.9	\$432.00	\$345.00
30	DWM-30-120	3 x 10	420	3.50	34.3	\$466.00	\$379.50

*for 208V figures, see product specification sheet, which can be found on warmup.com

2. Code	Accessories	Canada	USA
ACC-DGMTR	The Alligator Tester - Digital Multimeter.	\$25.00	\$20.00
DCM-SP-10K	Additional Floor Sensor for the 4iE®.	\$26.00	\$21.00
RL-240V25A	General purpose 25A/240V relay used to expand the switching capability of the Warmup thermostats. Mounts in single gang box.	\$106.00	\$85.00

3. Code	Thermostat	Canada	USA
6iE-04-CW-LC	Warmup's WiFi white 6iE®	\$299.00	\$279.00

4. Code	Optional Insulation	Canada	USA
WCI-01	Single 4'x2' Ultralight sheet with 3-in-1 capabilities: insulating, heat spreading, and decoupling.	\$38.00	\$29.28

StickyMat™ Project Examples

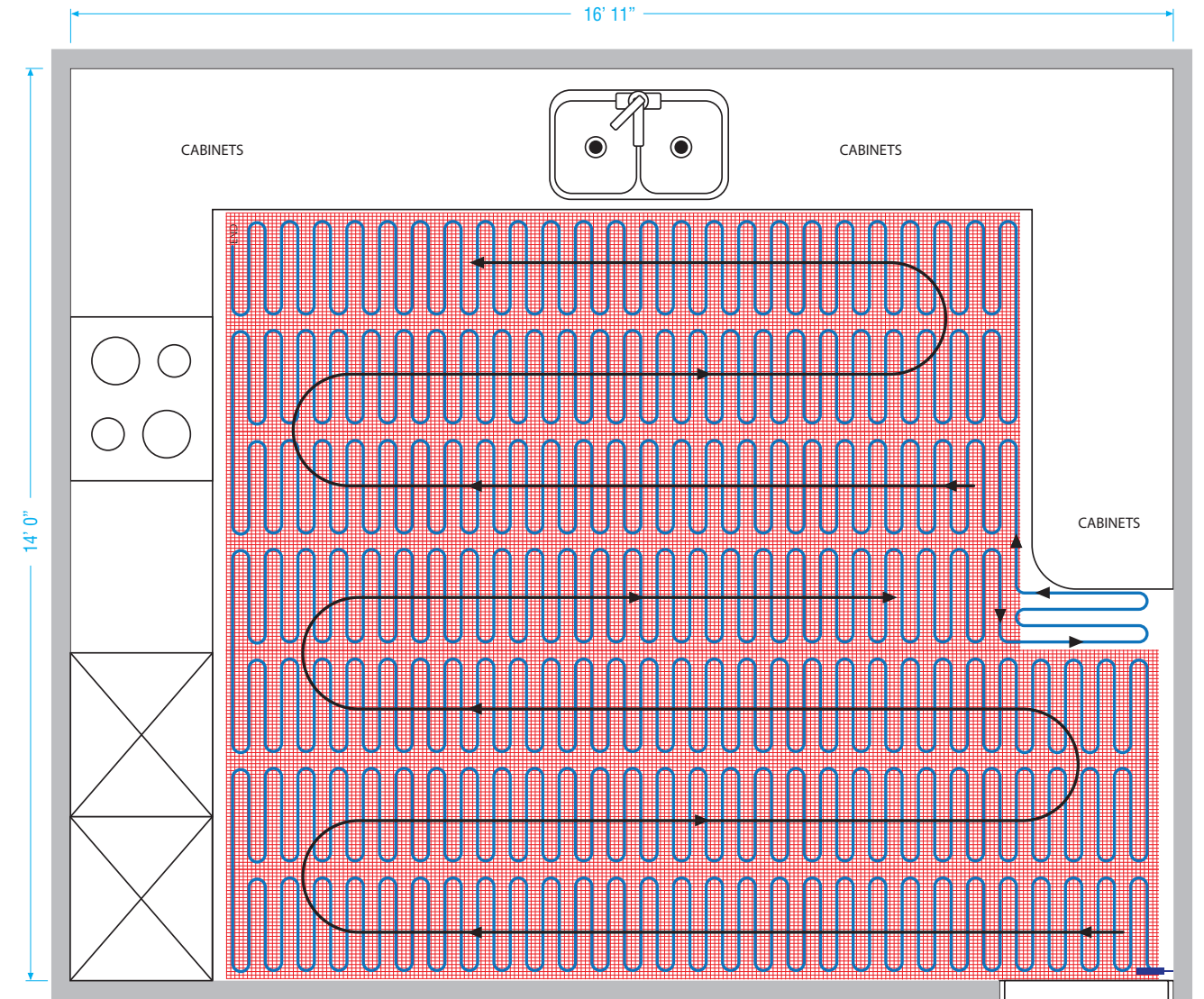
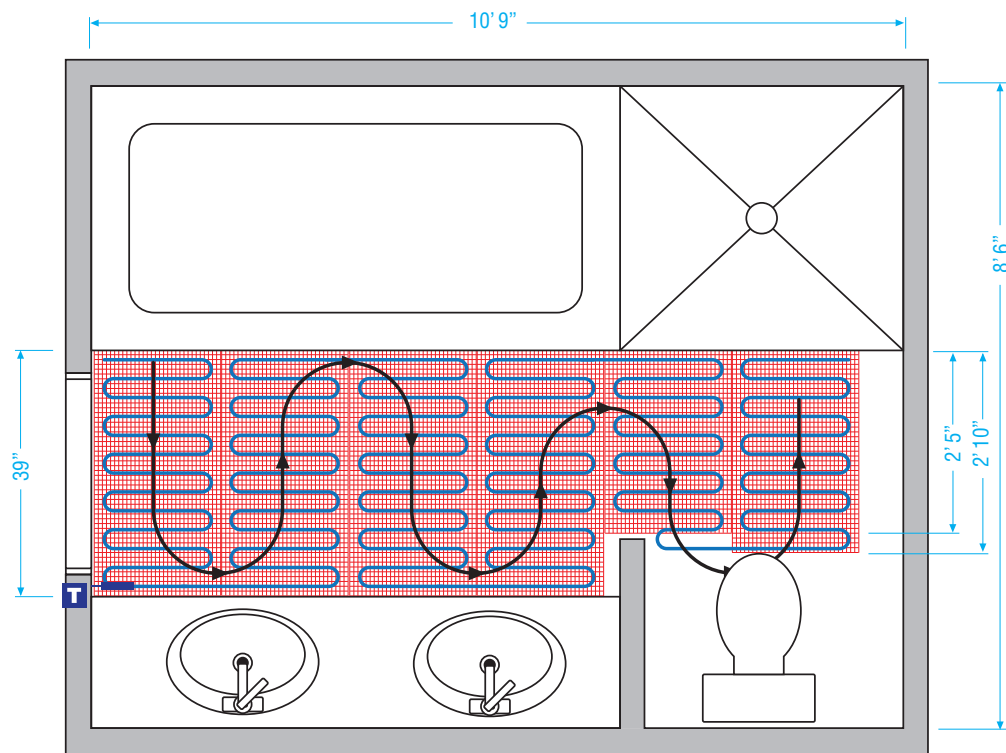

Size 89 sq. ft.		Price \$602.00		Type StickyMat™	
Total Room Area	89 SQ FT			Specifications	
Surface to be Heated	35 SQ FT			Voltage	120
Heating System	DWM-120-420 FLOOR HEATING MAT	\$390.50		Amps	3.5
Thermostat	6iE THERMOSTAT	\$279.00		Monthly Cost to Run	\$6.13
		Subtotal		Total BTU Equivalent	1,433

Size 237 sq. ft.		Price \$1,604.50		Type StickyMat™	
Total Room Area	237 SQ FT			Specifications	
Surface to be Heated	160 SQ FT			Voltage	240
Heating System	DWM 240-2100 FLOOR HEATING MAT	\$1,395.50		Amps	8.8
Thermostat	6iE THERMOSTAT	\$279.00		Monthly Cost to Run	\$21.21
		Subtotal		Total BTU Equivalent	7,165

FOIL System

For use under Carpet, Laminate and Floating Engineered Wood Floors

The Warmup FOIL system is an electric mat for floating floors that **requires no mortar**. The system can be customized for installation in regularly shaped spaces. The FOIL product is designed to be installed between underlay and the finished flooring.

All tested carpet pads are sufficient underlay. For laminate and wood installations, Warmup recommends the use of WIU insulation to provide better heat outputs and faster heat-up times.



Quote in 4 Easy Steps:

1. FOIL Heater
2. Accessories
3. Thermostat
4. Optional Insulation Underlay

Call Warmup for compatibility with LVT/LVP floors

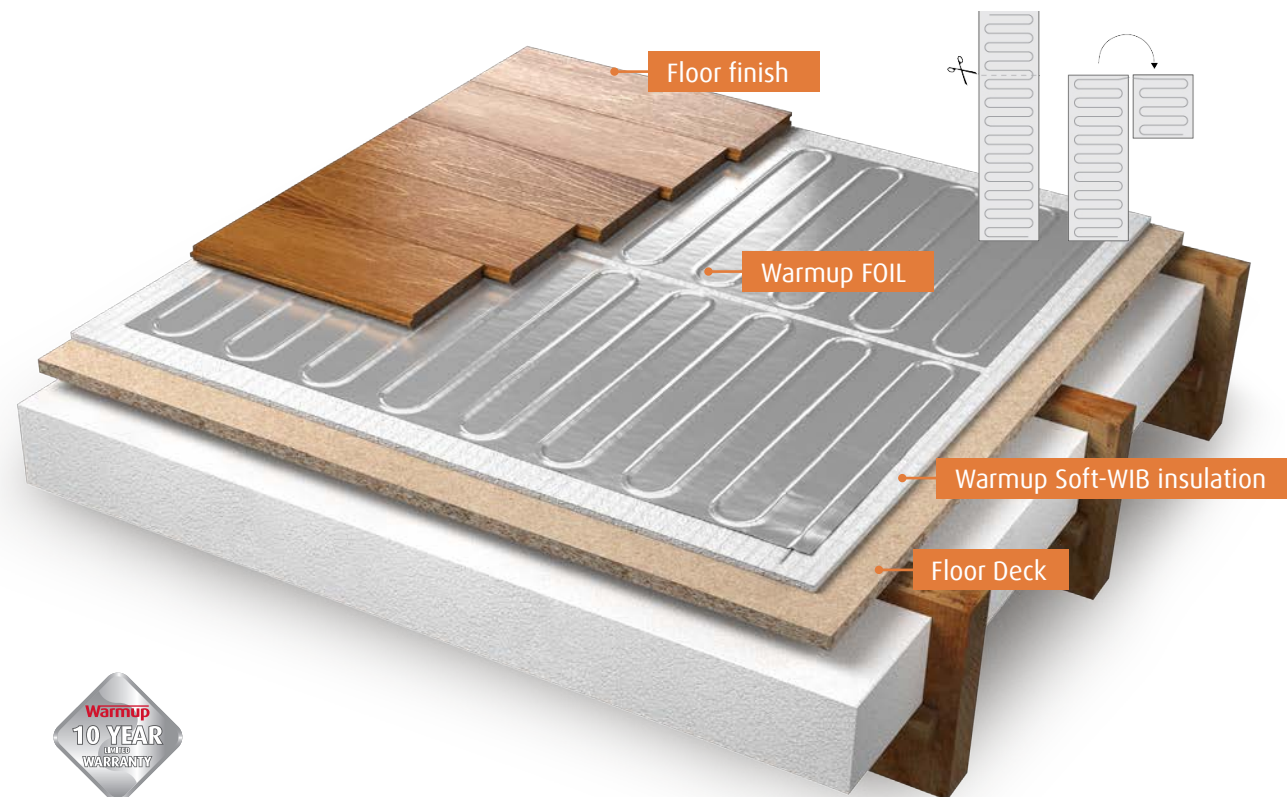

Area (sqft)	Code	Mat length (20" wide)	Wattage	Amps	Resistance (Ω)	Canada	USA
20	FOIL-20-240	12'	240	1.0	240	\$309.00	\$239.00
25	FOIL-25-240	15'	300	1.25	192	\$329.00	\$299.00
40	FOIL-40-240	24'	480	2.0	120	\$459.00	\$445.00
50	FOIL-50-240	30'	600	2.5	96	\$589.00	\$556.00
60	FOIL-60-240	36'	720	3.0	80	\$709.00	\$668.00
70	FOIL-70-240	42'	840	3.47	69	\$829.00	\$779.00
95	FOIL-95-240	57'	1140	4.70	51	\$1,119.00	\$1,058.00
115	FOIL-115-240	69'	1380	5.71	42	\$1,249.00	\$1,182.00
130	FOIL-130-240	78'	1560	6.48	37	\$1,429.00	\$1,335.00
140	FOIL-140-240	84'	1680	7.05	34	\$1,579.00	\$1,439.00

Code	Accessories	Canada	USA
ACC-DGMTR	The Alligator Tester - Digital Multimeter.	\$25.00	\$20.00
RL-240V25A	General purpose 25A/240V relay used to expand the switching capability of the Warmup thermostats. Mounts in single gang box.	\$106.00	\$85.00
DCM-SP-10K	Additional Floor Sensor for the 6iE®.	\$26.00	\$21.00
TAPE-AL	Aluminum Foil Tape for grounding. Sold in 90ft roll.	\$27.00	\$23.00
ACC-WATCHDOG	The Watch Dog Tester - Sounds an alarm when connected to a broken heating cable.	\$25.00	\$20.00

Code	Thermostat	Canada	USA
6iE-04-CW-LC	Warmup's WiFi white 6iE®	\$299.00	\$279.00

Code	Optional Insulation Underlay	Canada	USA
WIB-SOFT-1/4-110	Warmup Insulation Underlay 110 sqft rolls.	\$150.00	\$115.50

*The FOIL product requires an underlay. Approved carpet padding and polyurethane sound barriers are acceptable underlay.

Thermostats

“Alexa, set living room thermostat to 85 degrees”



Code	Orientation	Color	WiFi/ Non WiFi	Max Load	Canada	USA
6iE-04-CW-LC	Portrait	White	WiFi	15A	\$299.00	\$279.00
DCM-SP-10K*	N/A	White	N/A	N/A	\$26.00	\$21.00
RL-240V25A	N/A	N/A	N/A	25A	\$104.00	\$82.50

*all thermostat boxes include one floor sensor DCM-SP-10K

**all 4iE® models have a built-in Class A GFCI and can operate systems at 120, 208 or 240V, via ambient and floor sensor.

THERMOSTAT INSTALLATION

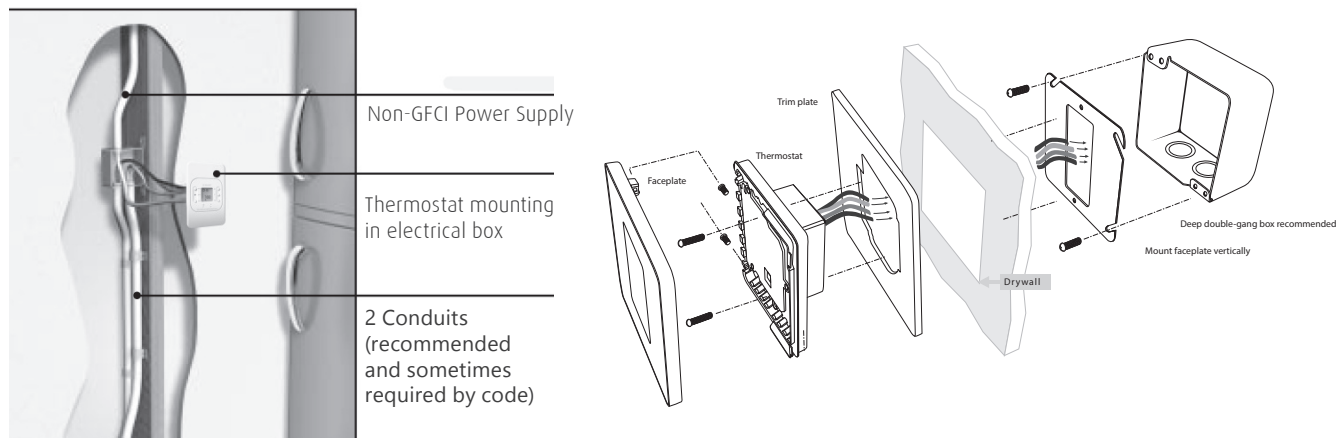

Insulation Boards Under Tile

Warmup Ultralight is a specialized composite board designed for floor heating applications. Manufactured as flat, flexible, sheets they are water

and mold resistant. The top surface incorporates a heat spreading aluminum layer combined with non-woven fleece.

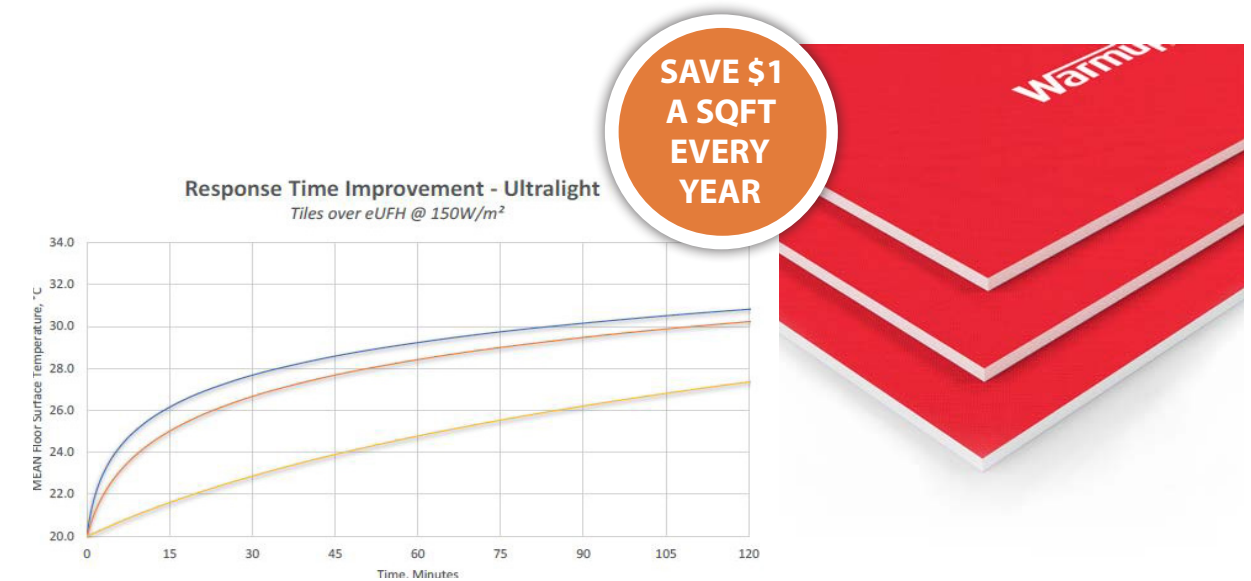

Code	Description	Canada	USA
WCI-01	Single 4'x2' Ultralight sheet with 3-in-1 capabilities: insulating, heat spreading, and decoupling.	\$38.00	\$29.28

Insulation Underlay For Floating Floors

Warmup Insulation Underlay is a thin polystyrene insulation barrier with effective acoustic properties to reduce contact noise.

It sits between the cold subfloor and Warmup FOIL Heating System, prevents heat loss and makes the underfloor heating system more efficient and effective. The Foil backing acts as an effective moisture barrier.



Code	Description	Canada	USA
WIB-SOFT-1/4-110	Warmup Insulation Underlay 110 sqft rolls.	\$150.00	\$115.50

Turn your bathroom
into a spa™

Warmup

Bathroom Collection

What will take your space from Bath to Spa?

Warmup's high quality stainless steel towel warmers are a cost-effective add-on to any bathroom. They are simple to install and not only do they warm and dry towels, but provide added heat to the room. Warmup Towel Warmers heat up to 145°F and are available in multiple finishes and models.

Did you know you can resolve steamy bathrooms and fogged mirrors for less than \$100? Warmup **Mirror Defoggers** connect straight to your light switch. You can stick them behind almost any new or existing mirror and regain the convenience of a clear, fog-free mirror.

Warmup **floor heating** is more than a bathroom luxury. For around \$1,000, it is a tested, proven and reliable heat source in any bathroom, replacing wall-heaters or baseboards. Our heated floors come with over 25 years of experience, R&D and 2 million applications worldwide. That's over 4 million warm feet! Radiant heated floors are the healthiest way to heat a space. They provide complete design freedom and require zero maintenance.

With our SafetyNET Guarantee and 30-Year product warranty, you can choose Warmup with confidence. Go ahead and Warmup your floor™.



Brushed Stainless

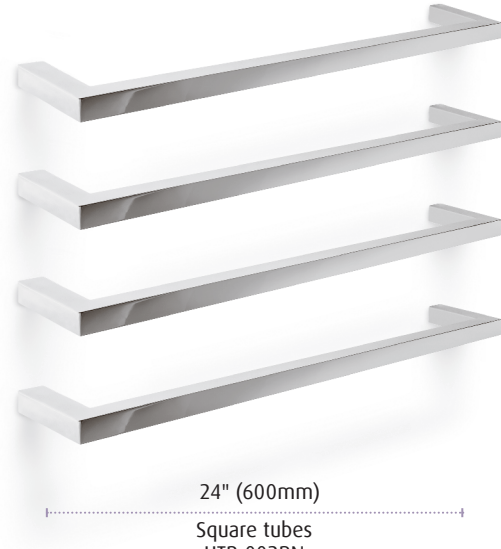

24" (600mm)

Square tubes
HTR-002BN

DID YOU KNOW?
Warmup's unique 001 and 002 models are recommended in sets of 4 or more for best results. Mounting bracket included.



36" (920mm)

24.5" (620mm)

Square tubes
HTR-107BN



53" (1340mm)

24.5" (620mm)

Square tubes
HTR-110BN

Code	Description	Wattage	Canada	USA
HTR-002BN	Single brushed nickel square tube towel warmer	14	\$164.00	\$130.50
HTR-107BN	Ladder style square tube towel warmer with 7 bars	80	\$596.50	\$477.00
HTR-110BN	Ladder style square tube towel warmer with 10 bars	110	\$768.50	\$614.50

Matte Black

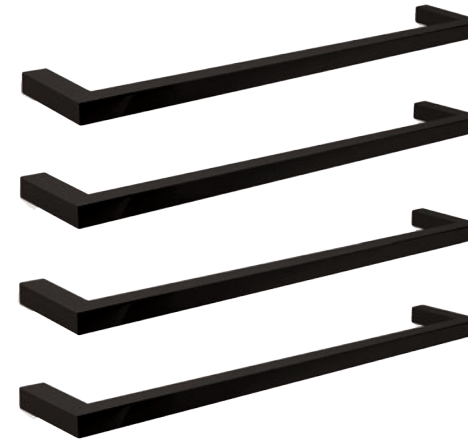

24" (600mm)

Square tubes
HTR-002MB

DID YOU KNOW?
Warmup's unique 001 and 002 models are recommended in sets of 4 or more for best results. Mounting bracket included.

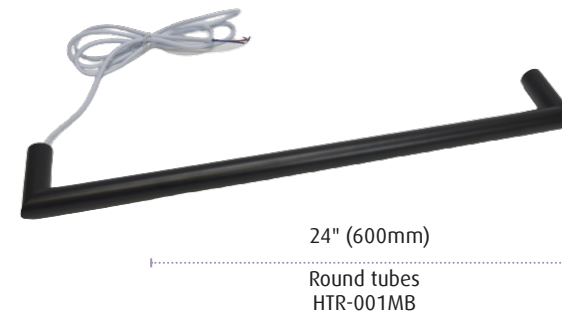

24" (600mm)

Round tubes
HTR-001MB



24" (600mm)

Square ladder
HTR-091MB

[SEE MORE AT WARMUP.COM](http://www.warmup.com)

Code	Description	Wattage	Canada	USA
HTR-001MB	Single matte black round tube towel warmer	14	\$148.50	\$118.00
HTR-002MB	Single matte black square tube towel warmer	14	\$164.00	\$130.00
HTR-091MB	Ladder type matte black square tube towel warmer	60	\$475.00	\$379.50

Polished Stainless



24" (600mm)
Round tubes
HTR-001PC

DID YOU KNOW?

Warmup's unique 001 and 002 models are recommended in sets of 4 or more for best results. Mounting bracket included.

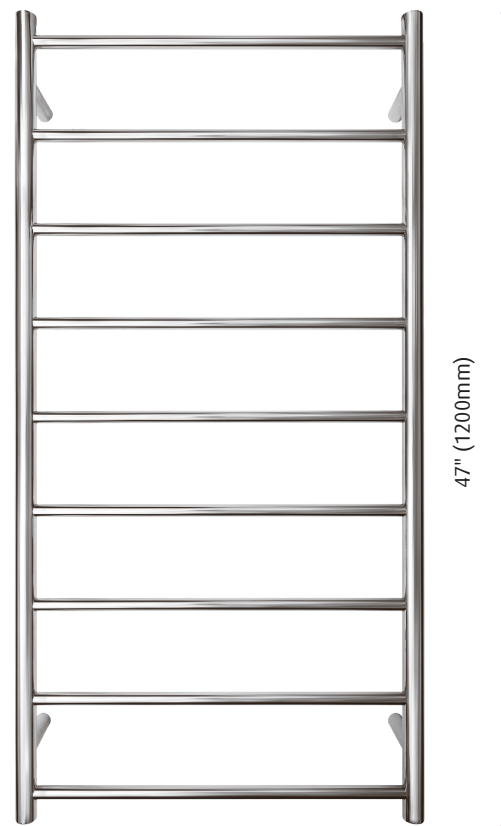

24.5" (600mm)

Round tubes - straight
HTR-092PC

47" (1200mm)

Mirror Defoggers



Code	Description	Wattage	Canada	USA
HTR-001PC	Single polished chrome round tube towel warmer	14	\$148.50	\$118.00
HTR-092PC	Ladder style towel warmer with 9 bars	90	\$599.00	\$493.50

Mirror defoggers are the little things that make all the difference.



- Available in 6 sizes
- Adhesive backed
- Easy to install
- Fog free mirror in seconds
- Fits most mirrors
- Low running cost
- Connects to existing light switch

Code	Description	Shape	Wattage	Canada	USA
MD-1624	Mirror Defogger Pads 16 x 24	Rectangular	47W	\$98.00	\$78.50
MD-1826	Mirror Defogger Pads 18 x 26	Rectangular	57W	\$114.50	\$91.50
MD-2432	Mirror Defogger Pads 24 x 32	Rectangular	96W	\$160.00	\$128.50
MD-15	Mirror Defogger Pads 15"	Circular	20W	\$65.00	\$52.00
MD-20	Mirror Defogger Pads 20"	Circular	41W	\$114.50	\$91.50
MD-25	Mirror Defogger Pads 25"	Circular	65W	\$155.00	\$124.00

Plan for a safe & maintenance-free winter with Warmup® Snow Melting Solutions



Why get a Snow Melting System?

The obvious part is that **not having to shovel** seems like a pretty good thing. But there are other advantages beyond convenience:

- (1) A snow melting system also **protects you from liability**. If you own a business and worry about slip and falls, this is a reliable solution 24/7.
- (2) **Pavement damage**: if you pay someone to shovel with a truck or a 4-wheeler, blades can cause damage to your concrete and reduce its lifespan. And over expensive pavers it is even worse.
- (3) **Damage to landscaping**: the salt spread on your driveway or walkway doesn't mysteriously disappear. It dissolves with the melting ice and snow and runs into the concrete and surrounding landscaping. This will damage your concrete's top coat and can easily kill plants you'll have to replace in the spring.

What would you need to Install a Snow Melting System?

Getting a snow melting system is simpler than you'd think. Most systems are **comprised of 3 elements**: a set of heating mats (or cables), a controller and a sensor.

1. Heating Mats or Cables



2. Controller



3. Sensor



Residential Driveway

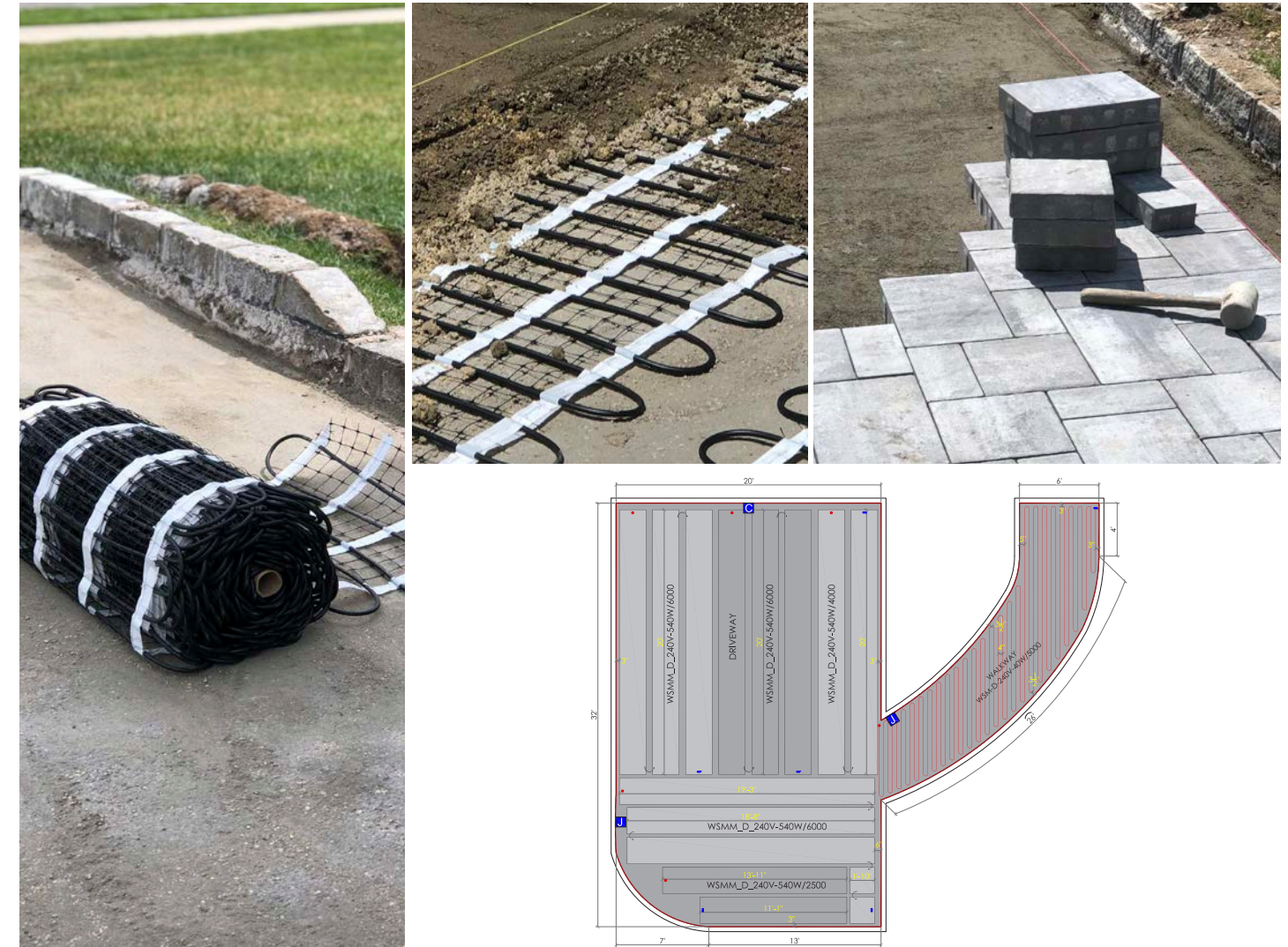

Size		Price	Type	
750 Sqft		\$7,521.00	WSMM and WSM	
Total Area	750 sqft		Specifications	
Heating System	3 2'x60' mats	\$3,415.50	Voltage	240
	2'x40' mat	\$790.50	Amps	122.9
	2'x25' mat	\$540.00	Winter Cost to Run	\$285
Controller	500' of loose cable	\$960.00	Total Wattage	29,500
	WSM-252W	\$2,034.50		
		Subtotal	\$7,740.50	

Hydronic or Electric?

A snow melting system can be powered by a boiler with a glycol-mix circulating through tubes, or it can be powered by electricity running through cables. Both will deliver the same end result. Choosing one over the other can be a factor of utility costs in your area, but usually comes down to size.

Beyond 1,000 sqft it may be more cost-effective to consider a hydronic set-up. Costs will likely be higher upfront due to the mechanical set up required (boiler, pump, valves, etc) but may be more efficient over the long run. Below 1,000 sqft and most certainly for smaller applications like access ramps and residential walkways and driveways, electric systems can be compellingly effective because the low upfront cost to install the system.

But, "electricity is expensive..."

Not if your system runs efficiently. While a KiloWatt usually costs more than a Therm (gas), Electric systems only run for about 5 to 8 hours during a snow fall. Did you know that a Hydronic system runs 24/7 to prevent the liquid from freezing all winter?

When you take about 13 "snow events" in Chicago on a typical winter, that means your system will have run 13 x 8 hours. For a 12 Kw system (about 300 sqft) that means you'll have spent \$149 for the whole winter running your driveway. True, electricity isn't cheap, but when used efficiently, it can be a lot less than you had imagined.

Designing your System

The main principle is that "it melts where it is installed". Because it is buried in sand (pavers, asphalt) or concrete you don't need to melt every square inch of your walkway or driveway. Typically a 2ft path on a 4ft-wide walkway suffices. Similarly, melting tire-tracks rather than the whole driveway can be very cost-effective.

While it is mostly a personal choice, tire-tracks are a great option unless you get no sun or passive melting on the driveway. You should also consider "run-off" and plan for the walkway or driveway to be heated so as to ensure melting snow and ice is routed away from the area.

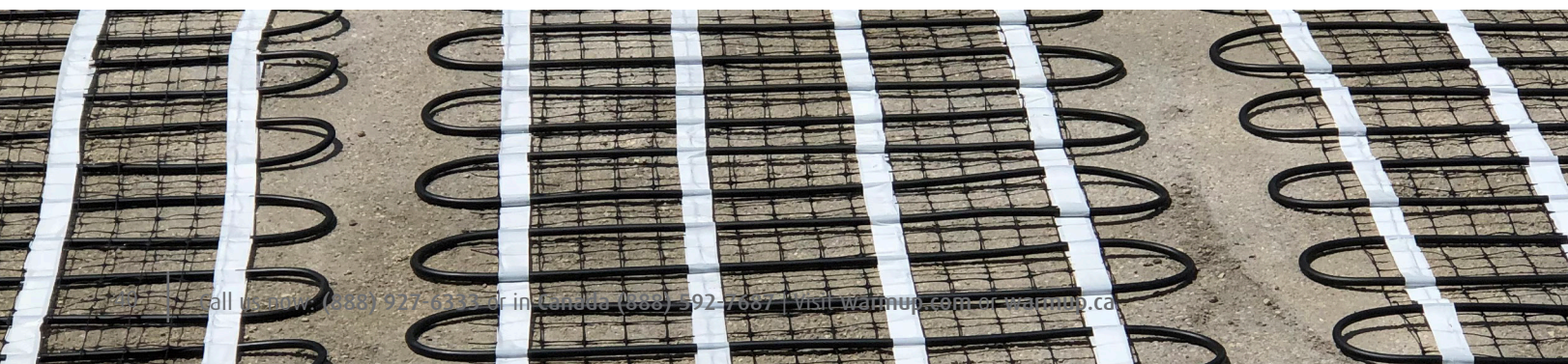

Cables or Mats?

Warmup offers convenient heating mats in 2ft and 3ft width. These are great for tire-tracks and straight runs. Cables are a better choice on steps and off-shaped areas with curves. Ultimately, both perform the same task at the same efficiency. Let Warmup design the best system by submitting your sketch or layout to ussales@warmup.com.

Voltage and Amperage

A typical system will be designed and operated at 240 volts. This is true for residential and commercial, but Warmup also offers commercial voltages at 208 volts, 480 volts and 600 volts (in Canada). Advanced systems can be wired on 3-phase power as well. Assume the easiest set up is a 240 volt system but let Warmup help you design the best system for you.

A key component of your project will be to determine that you have sufficient amperage to operate your system. It will typically take 60 to 80 amps to run a typical residential driveway, although that will vary with size. Check with your contractor or electrician what amperage may be available for your project. There are many options we can play with to design the right system for you. A quick estimate would be to account for 1 amp for every 6 sqft of heated area.

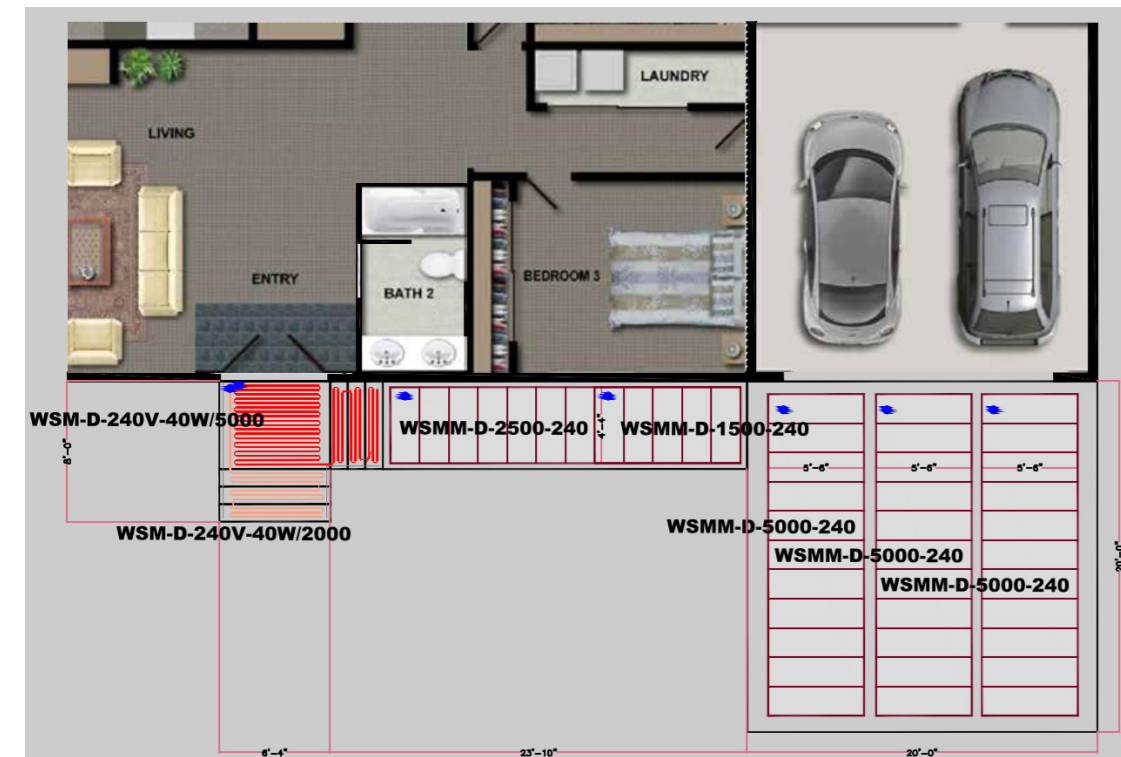

Snow Melting Mats

For regular layouts and spacing under concrete, pavers and asphalt pours.

Warmup systems are ideal to provide snow-free access to the house and prevent injuries on stairs and walkways. They are commonly used in concrete pours, asphalt driveways and paved walkways.

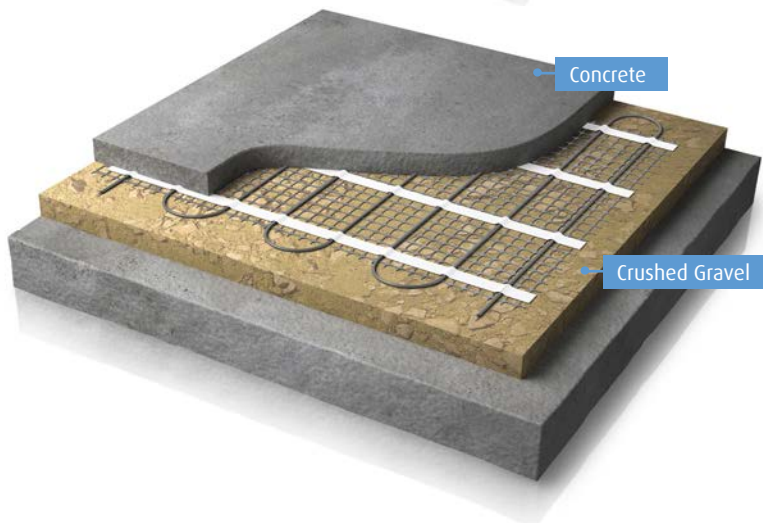
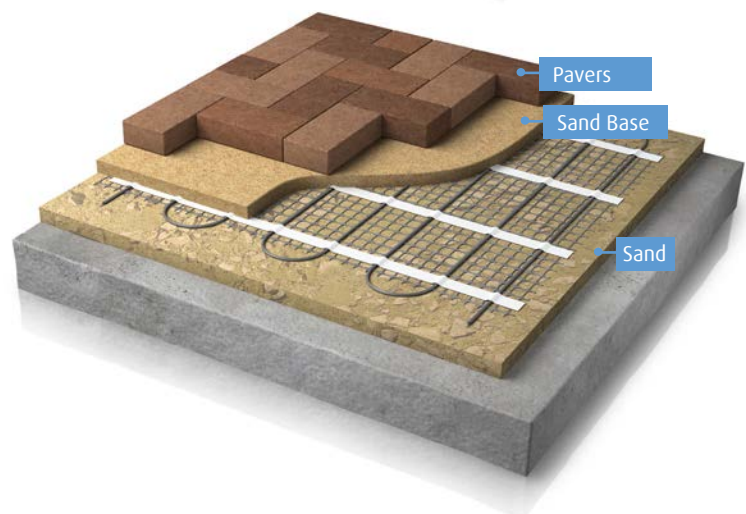
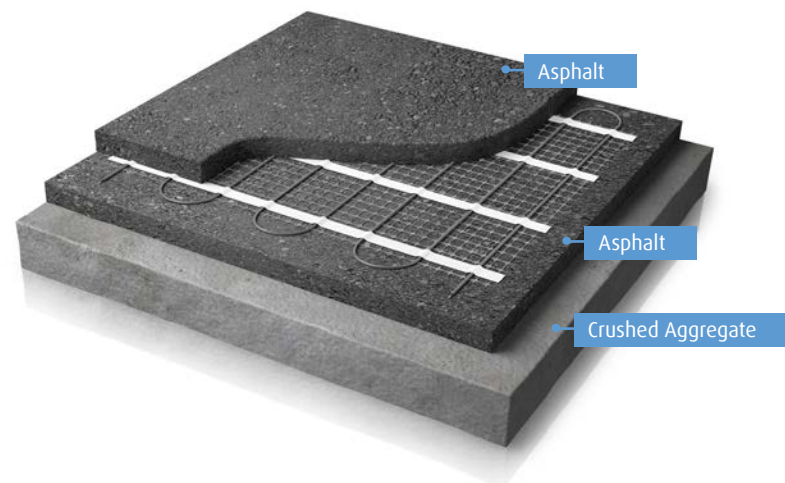

Mats are 2ft or 3ft wide and with a 3" cable spacing providing 50w/sqft for optimum results under even the harshest conditions.

FEATURES & BENEFITS

- Versatile installation in asphalt, concrete or under pavers
- Dual conductor cable, one-point connection
- Available in a wide range of lengths to suit your requirements
- Available in 2 ft and 3 ft wide rolls

TECHNICAL DATA

- Operating voltage: 208, 240, 277, 480 and 600V
- Output rating: 50W/sqft at 240V
- Rated to a maximum temperature of 464°F (240°C) under asphalt pours
- Cold tail length: 16'4"
- 10-Year Warranty



Voltage	Area (sqft)		Mat Length (ft)	Wattage	Amps	Resistance (Ω)	Canada	USA
240V*	10	WSMM-240/500	5	500	2.1	115.20	\$224.00	\$224.00
	20	WSMM-240/1000	10	1000	4.2	57.60	\$374.00	\$298.50
	30	WSMM-240/1500	15	1500	6.3	38.40	\$502.00	\$401.00
	40	WSMM-240/2000	20	2000	8.33	28.80	\$585.50	\$468.50
	50	WSMM-240/2500	25	2500	10.43	23.00	\$675.50	\$540.00
	60	WSMM-240/3000	30	3000	12.5	19.20	\$763.00	\$610.50
	70	WSMM-240/3500	35	3500	14.6	16.46	\$875.00	\$700.50
	80	WSMM-240/4000	40	4000	16.7	14.40	\$988.50	\$790.50
	90	WSMM-240/4500	45	4500	18.8	12.80	\$1,073.00	\$858.33
	100	WSMM-240/5000	50	5000	20.86	11.50	\$1,207.00	\$965.50
	120	WSMM-240/6000	60	6000	25.0	9.60	\$1,466.50	\$1,172.50

Voltage	Area (sqft)	Code	Mat Length (ft)	Wattage	Amps	Resistance (Ω)	Canada	USA
240V*	30	WSMM-240/3x10	10	1500	6.3	38.4	\$502.00	\$401.00
	60	WSMM-240/3x20	20	3000	12.5	19.2	\$767.00	\$613.50
	75	WSMM-240/3x25	25	3750	15.6	15.6	\$899.50	\$719.50
	90	WSMM-240/3x30	30	4500	18.8	12.8	\$1,062.50	\$850.00
	120	WSMM-240/3x40	40	6000	25.0	9.6	\$1,322.00	\$1,138.50

*all mats can be connected to 208V and 277V, single phase and 3 phase power. Please check our Technical Data Sheets for variations to Wattage output and Amperage Load under different Voltages.

Voltage	Area (sqft)	Code	Mat Length (ft)	Wattage	Amps	Resistance (Ω)	Canada	USA
480V	30	WSMM-480/1500	15	1500	3.12	153.84	N/A	\$401.00
	40	WSMM-480/2000	20	2000	4.16	115.38	N/A	\$468.50
	60	WSMM-480/3000	30	3000	6.25	76.8	N/A	\$610.50
	80	WSMM-480/4000	40	4000	8.33	57.62	N/A	\$790.50
	120	WSMM-480/6000	60	6000	12.50	38.40	N/A	\$1,138.50

Code	Accessories	Canada	USA
WSM-NMP	Branded Name Plate for use with Warmup Snow Melt Heater installations (NEC426-13).	\$50.00	\$40.00
ACC-DGMTR	The Alligator Tester - Digital Multimeter.	\$25.00	\$20.00
SR-ZT-100	Bag of 100 Heavy Duty Zip Ties. 7" long. For use with WSM, WODH and SR cable series. 50lbs load bearing capacity.	\$25.00	\$20.00
RK-EO	Repair kit for Warmup® outdoor heating cable.	\$13.00	\$10.00

Snow Melting Cables

For custom layouts and spacing under concrete, pavers and asphalt pours.

Snow Melting Cables are the loose equivalent of the Mats. The cables are reinforced with advanced fluoropolymer coatings to form a cable jacket that can withstand traffic and setting material. Warmup's

Cables are completely grounded and safe for installation under asphalt, pavers and concrete. Choose the loose format for stairs and off-shaped areas, and combine with Mats wherever necessary.

FEATURES & BENEFITS

- Versatile installation in asphalt, concrete or under pavers
- Flexible cable: quick and easy to install in every configuration
- Dual conductor cable, one-point connection
- Available in a wide range of lengths to suit your requirements



TECHNICAL SPECIFICATIONS

- Operating voltage: 208, 240, 277 and 480V
- Output rating: 12W / linear foot at 240V
- Energy efficient twin-conductor heating cable of 1/4"
- Wire jacket rated to take maximum asphalt pour temperatures of 464°F (240°C)
- Cold tail length: 16'4"
- 10-Year Warranty



Voltage	Length (ft)	Code	Cable Spacing			Wattage	Amps	Resistance (Ω)	Canada	USA
			3"	4"	5"					
240V*	84	WSM-240/1000	20	27	34	1000	4.2	57.1	\$284.50	\$227.50
	168	WSM-240/2000	43	57	72	2000	8.3	28.9	\$454.00	\$363.50
	209	WSM-240/2500	51	67	84	2500	10.4	23.1	\$543.00	\$432.50
	251	WSM-240/3000	62	84	104	3000	12.5	19.2	\$626.50	\$501.00
	330	WSM-240/4000	85	110	135	4000	16.90	14.2	\$798.00	\$637.50
	420	WSM-240/5000	100	140	170	5000	20.86	11.5	\$958.50	\$766.50
	500	WSM-240/6000	122	181	200	6000	25.0	9.6	\$1,155.50	\$924.50

*all mats can be connected to 208V and 240V, single phase and 3 phase power. Please check our Technical Data Sheets for variations to Wattage output and Amperage Load under different Voltages.

Voltage	Length (ft)	Code	Wattage	Amps	Resistance (Ω)	Canada	USA
480V	84	WSM-480/1000	1000	2.08	230.77	N/A	\$241.00
	209	WSM-480/2500	2500	5.20	92.30	N/A	\$458.00
	342	WSM-480/4000	4000	8.33	57.62	N/A	\$675.50
	500	WSM-480/6000	6000	12.50	38.4	N/A	\$960.00

Voltage	Length (ft)	Code	Wattage	Amps	Resistance (Ω)	Canada	USA
600V	84	WSM-600/1000	1000	1.7	360	\$236.00	N/A
	209	WSM-600/2500	2500	4.2	144	\$449.00	N/A
	342	WSM-600/4000	4000	6.7	90	\$662.00	N/A
	500	WSM-600/6000	6000	10	60	\$941.00	N/A

Code	Accessories	Canada	USA
WSM-NMP	Branded Name Plate for use with Warmup Snow Melt Heater installations (NEC426-13).	\$50.00	\$40.00
ACC-DGMTR	The Alligator Tester - Digital Multimeter.	\$25.00	\$20.00
SR-ZT-100	Bag of 100 Heavy Duty Zip Ties. 7" long. For use with WSM, WODH and SR cable series. 50lbs load bearing capacity.	\$25.00	\$20.00
DCM-FB-82	Metal fixing strips to fix the heating cable - 83 ft long.	\$133.00	\$108.00
RK-OUTDOOR	Repair kit for Warmup® outdoor heating cable.	\$13.00	\$10.00

Sensors, Panels, and Controls

To control a system you will need two things: a relay panel and a controller. Often times, these two devices are put together in one unit. As an option, you may also need a sensor to trigger the system. Those are the 3 components needed, so let's look at your options:

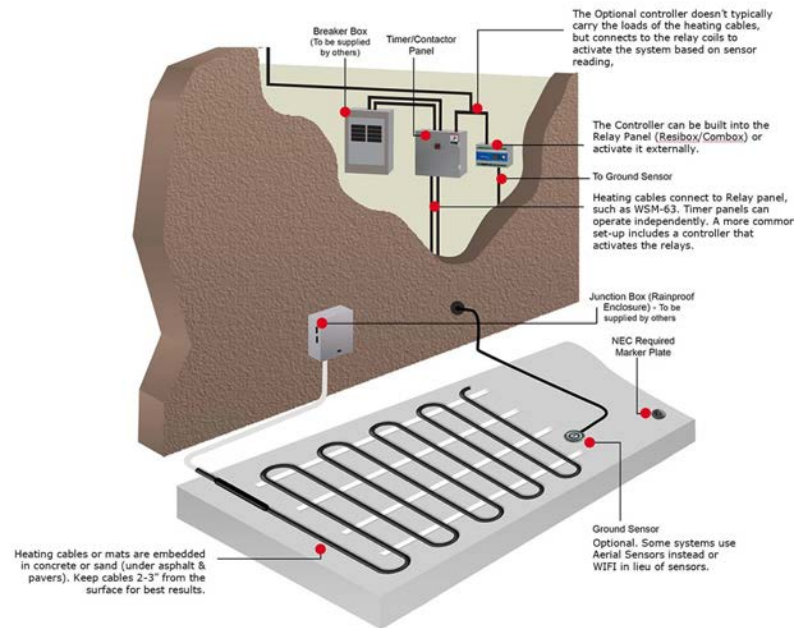

The simplest set up is with a Timer panel like the WSM-63. This set up has all the relays built-in and has an adjustable timer that you can manually start to activate the system on snow days. There are no controls or sensors required.

Another great set up for smaller areas up to 300 sqft is with the DS control series. These devices are ideal for walkways, tire-tracks and residential projects. The sensor is built-into the controller and the heating mats connect directly to it. So there is nothing else to buy.

The more advanced set-ups will combine a smart panel with a sensor. A popular option for larger projects are the RESIBOX and COMBOX systems which can control large applications and have built-in GFEP protection. They are triggered by the AIRSENSE sensor mounted on the wall.

An upgraded version of this is with the WSM-252, which offers the same feature as well as WIFI connectivity. This allows the device to activate based on the weather forecast once you download the Warmup WSM app .

Snow Melting Controls

A control for every project and for every budget



DS Series (ODC-ASE-DS2C/5C)



WSM-63 Timer Panel



WSM-252W WiFi Panel

Controllers

Code	Description	Canada	USA
ODC-ASE-DS2C	Wall-mounted controller with built-in sensor and 30A capacity (240V). For Snow Melting.	\$869.00	\$695.50
ODC-ASE-DS5C	Wall-mounted controller with built-in sensor and 2x30A capacity (240V). For Snow Melting.	\$1,118.00	\$894.50
ODC-CDP-2	Indoor control panel for ASE-DS controllers. Fits any single gang electrical enclosure.	\$335.00	\$268.00
WSM-63	Timer panel with 252A capacity. Operate manually as Timer, or combine with optional sensors.	\$2,142.50	\$1,713.50
ODC-RESIBOX3	GFEP protected 30A controller activates Snow Melting systems. Use with CIT, GIT and AirSense sensors.	\$4,908.00	\$4,097.50
ODC-COMBOX600	4x50A-3-phase relays for this GFEP controller that can switch multiple zones. Plug-and-Play format.	\$7,624.00	\$6,099.50
WSM-252W	WiFi panel activates with the weather forecast and operates on Smartphone Application.	\$2,543.00	\$2,034.50
ODC-AIRSS	Outdoor moisture and temperature sensor.	\$1,055.00	\$843.50
ODC-AIRSS-B	Mounting bracket for AirSense sensor.	\$267.00	\$213.50
GF-1	In-line GFEP protection for one outdoor heating circuit up to 60A at 120/208/240V.	\$835.59	\$675.00
GF-2	In-line GFEP protection for two outdoor heating circuits up to 63A each at 120/208/240V.	\$1,157.46	\$935.00

PRO TIP: When GFEP is required by code, consider the in-line protection of the GF-1 and GF-2 instead of sourcing an expensive GFEP breaker.



GF-1



ODC-COMBOX600



WSM-252W WiFi Panel

Other available Controls and Sensors

Code	Description	Canada	USA
ODC-GIT-1	Gutter sensor. Measures moisture and temperature. Active below 38°F.	\$1,369.00	\$1,090.00
SM-SIT-6E	Surface-mounted snow and ice sensor. Detects moisture and temperatures. Triggers below 38°F for energy-efficient operation. Easy mounting in slabs with multiple conduit connections.	\$3,163.00	\$2,515.00
SIT-6E-H	Housing for SIT-6E sensor	\$252.35	\$202.00
ODC-ET02-4550	Programmable controller for roof and pavement applications, 115/230 VAC, 3 x 15 Amp dry contact.	\$1,158.75	\$926.00
ODC-ETOR-55	Roof Sensor for use with Snow/Ice Control USET02-4450 - Detects moisture, temperature and precipitation.	\$643.00	\$514.00
ODC-ETOG-56	Snow and Ice melting pavement sensor.	\$899.00	\$720.00
ODC-ETOK	Installation cup for the Snow and Ice Melting Ground Sensor USETOG-56.	\$114.50	\$91.50



Plan for a safe & maintenance-free winter with Warmup® Pipe Freeze Protection

WHAT'S IN A SYSTEM?

Why would you need a pipe freeze protection system?

Consider this: a gallon of water, when frozen, will expand to a volume 9% greater than the original gallon. So it is no surprise that a fully or partially frozen pipe will swell up and crack, in particular when there is trapped air in the pipe.

A bulge or crack in a pipe with ice seeping out is a clear indication of a burst pipe. **Occasionally, however, the pipe may look fine and a homeowner may not see the small fractures caused by ice expansion.** Unfortunately, once the ice inside a frozen pipe begins to melt and water seeps out, it is already too late. **Depending on the extent of the damage, total cleanup costs from a busted pipe can soar to tens of thousands of dollars.** State Farm Insurance estimates the average insurance claim for water damage from frozen pipes is approximately \$15,000.

How does it work ?

If a building owner knows that a certain part of a structure with active water pipes may experience temperatures below freezing, the smart solution is to install a heating cable. **When combined with an integrated thermostat, the system is automatically turned "on" when temperatures drop below freezing.** The cables provide the needed level of heat to keep the pipes from freezing but not enough to heat the water inside of the pipes. The thermostat provides automatic control of the system so it saves energy by powering the cable only when required. For optimal performance of the system, pipe insulation can be installed over the cable to help retain heat, and plastic pipes can be wrapped in aluminum foil so the heat is dissipated evenly in the pipe

The benefit of this design is that the cables are installed once and left mounted on pipes for years — even when temperatures drop as low as -40°F (-40°C).

Self-regulating cables are built around a carbon core that expands and contracts with the ambient temperature. The colder it is, the more the core contracts and conducts the heat between the two power lines. So the cable automatically gets hotter as it gets colder. It is still recommended to tie it into a thermostat in order to shut it off completely when temperatures are consistently above 40F.

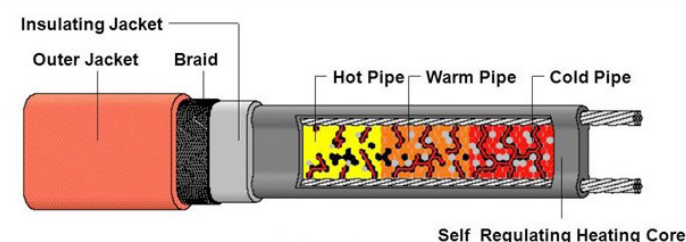
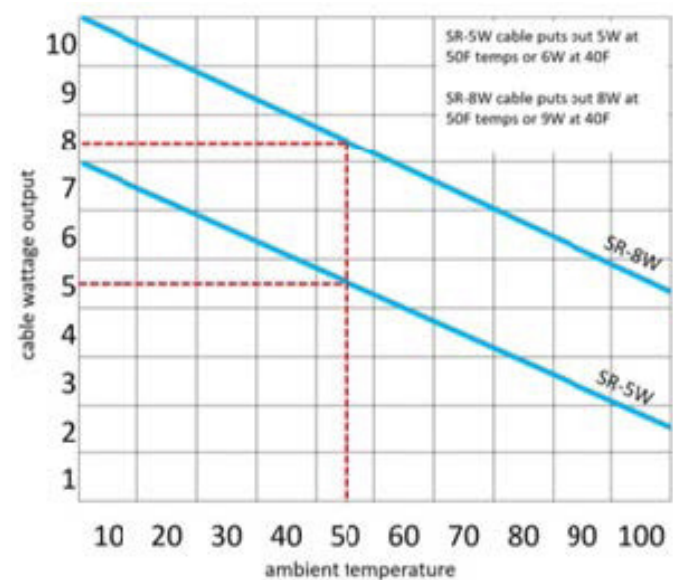

WHAT IS THE WARMUP SOLUTION AND WHY DO YOU NEED IT?

Warmup offers a full range of cables for all types of pipes, residential and commercial. Our residential solutions include a jacketed and unjacketed range. The former is universal, and the latter is limited to indoor residential pipes or RV/Mobile homes. All our products come in custom lengths cut from spool or in convenient plug-in kits.

HOW TO SPECIFY CABLE FOR YOUR PROJECT

Environment

The first consideration is whether you are protecting a pipe that is indoors or outdoors. Indoors means unheated crawlspaces, basements and garages (for example). For indoor applications, choose from either jacketed or unjacketed, for outdoor applications exposed to weather, always select jacketed cables and accessories.

Length of Cable

To “trace” a pipe you will need to gather two bits of information: (1) the total length of the pipe to protect and (2) the size and material of your pipe.

Gather the total length of pipe to be ‘traced’ and protected. Account for additional footage on spigots and valves (add 1ft). If your pipe makes a “T” connection, consider a “T splice” kit in the accessories, or double your cable footage for an out-and-back layout.

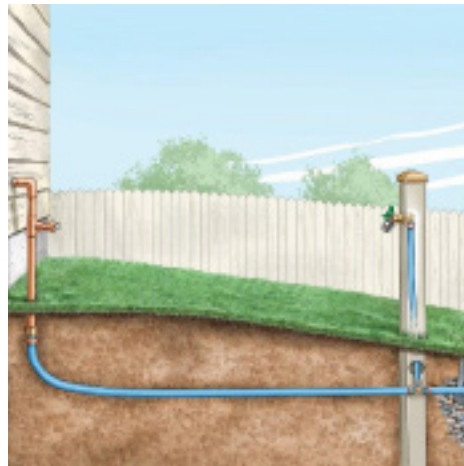

Size and Type of Pipe

Metal pipes are easier to protect because they conduct the heat better than PVC or Ceramic pipes. And of course, the larger the pipe diameter, the more output (wattage) it will take to prevent the contents from freezing. This is where you should consider two key improvements to your project:

1. Insulation: Even a half-inch of wrap-around insulation will drastically reduce the heatloss of your cable
2. Aluminum Tape: this will not only secure the cable to the pipe, but also help spread the heat from the cable farther.

The below chart is a summary view of what it would take to protect a pipe where winter temperatures dip into the -20F. For a complete chart, check Warmup’s spec sheets online.

Pipe Size / Insulation	None	1/2"	1"
1" Pipe	5W/ft	4W/ft	3W/ft
2" Pipe	10W/ft	8W/ft	5W/ft
4" Pipe	20w/ft	16W/ft	8W/ft

There are two ways to achieve the suggested wattage

For example: If you’re trying to protect a 20ft run of 2” PVC pipe in Chicago, you will need 20ft worth of 10 watt output. You can achieve this by doubling runs of 5 watt cable, or use an 8-watt cable and spiral it around the pipe. This way you have more feet of cable per foot of pipe.



What if my pipe is underground (and other tips)?

You should still insulate when possible as dirt/sand is a conductor and will reduce the cable’s effectiveness. It is also smart to consider where to put the cable around the pipe. In a pipe overhead, place the cable at 4-o’clock or 7-o’clock so that if you hit the pipe from below, you’re not hitting the cable directly. For pipe buried underground, place tyhe cable at 4 or 7 o’clock as well, to avoid hitting it with tools or a shovel.

Electrical Provisions

While most projects under 100ft do not typically cause electrical concern, larger runs will require considerations of dedicated circuits and circuits of the correct size. Speak to your electrician and consider the chart below. **For example, in Chicago, you can put up to 330ft of 5-watt cable on a 20A circuit**

	AMBIENT TEMPERATURE		120V				240v			
	AT START-UP		15A	20A	30A	40A	15A	20A	30A	40A
SR-5W	50°F	10°C	230	270	270	270	460	540	540	540
	32°F	0°C	230	270	270	270	460	540	540	540
	14°F	-10°C	180	210	270	270	360	420	540	540
	0°F	-18°C	140	190	270	270	285	380	540	540
	-20°F	-29°C	125	165	250	270	250	330	500	540
	-40°F	-40°C	110	145	220	270	220	295	440	540
SR-8W	50°F	10°C	150	200	210	210	300	400	420	420
	32°F	0°C	150	200	210	210	300	400	420	420
	14°F	-10°C	140	150	205	210	280	300	410	420
	0°F	-18°C	100	130	200	210	200	265	400	420
	-20°F	-29°C	85	115	175	210	175	235	350	420
	-40°F	-40°C	80	105	155	210	155	210	315	420

WHAT IS REQUIRED FOR A TYPICAL INSTALLATION?

A typical project will require a certain length of 5 watt or 8 watt cable. If you use our plug in kits (p7), consider an SR-PLUG that will switch off the cable above 50F to avoid excess usage. We recommend using our aluminum tape (SR-TAPE-AL) to help spread the heat around the pipe and of course, plan for insulating around the pipe as well.

If your project is more custom, you will need a length of SR cable from spool (p7). To power it up, you will need a SR-POWER-KIT which contains and END splice. You may need some SR-SFIT-TEE to make "T" connections or plan for out-and-back cable footage.

Finally, consider SR-TAPE-AL (Aluminum Tape) for conductivity and the recommended insulation.

Project Example:

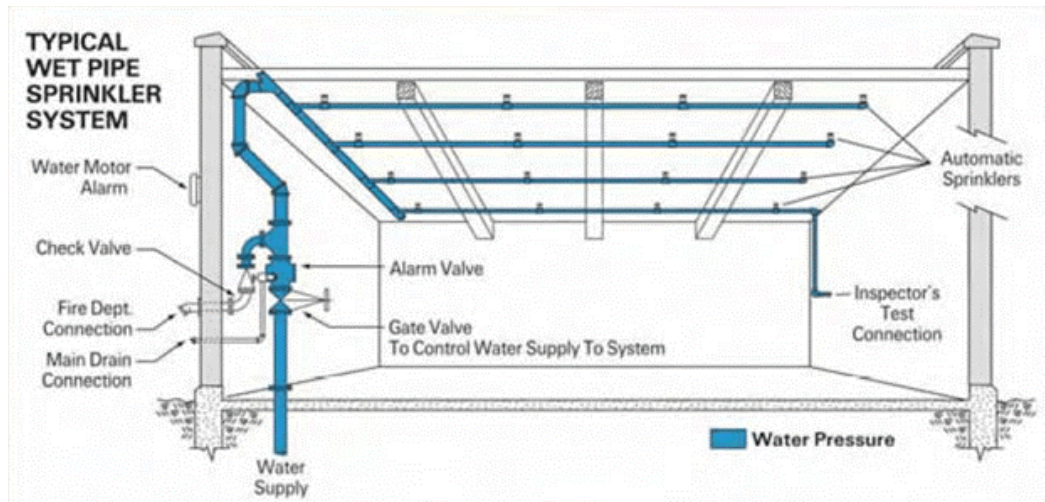

Cable Needs	125' of 5 watt/ft at 120V	\$884.00
Pipe Diameter	1" - 1/2" insulation wrap required	N / A
Accessories	Power connection, end caps x4, aluminum tape, and optional warning labels	\$468.50
Control	TF115-005	\$201.50
Subtotal		\$1,554.00

PIPE FREEZE PROTECTION CABLES: JACKETED

Self-regulating cable for indoor and outdoor applications

Available in cut-to-length spools or plug-in kits, the Warmup Cable is applicable on metal, PVC and ceramic pipes, sprinkler systems and sewer drains.

The nature of the Self-regulating Cable causes its output of 5 or 8 W/lin ft to vary automatically with the outside conditions, thereby guaranteeing the safeguard of ducts and pipes.

Code	Description	Canada	USA	
120V	SR-5W-1-250	Self-Regulated 16GA Cable, 120V, 5W/linear foot. Sold in 250' length spools.	\$2,033.00	\$1,803.00
	SR-5W-1-500	Self-Regulated 16GA Cable, 120V, 5W/linear foot. Sold in 500' length spools.	\$4,065.00	\$3,605.00
	SR-5W-1-1000	Self-Regulated 16GA Cable, 120V, 5W/linear foot. Sold in 1000' length spools.	\$8,129.00	\$7,210.00
	SR-8W-1-250	Self-Regulated 16GA Cable, 120V, 8W/linear foot. Sold in 250' length spools.	\$2,033.00	\$1,803.00
	SR-8W-1-500	Self-Regulated 16GA Cable, 120V, 8W/linear foot. Sold in 500' length spools.	\$4,065.00	\$3,605.00
	SR-8W-1-1000	Self-Regulated 16GA Cable, 120V, 8W/linear foot. Sold in 1000' length spools.	\$8,129.00	\$7,210.00
240V	SR-5W-2-250	Self-Regulated 16GA Cable, 240V, 5W/linear foot. Sold in 250' length spools.	\$2,093.00	\$1,856.00
	SR-5W-2-500	Self-Regulated 16GA Cable, 240V, 5W/linear foot. Sold in 500' length spools.	\$4,185.00	\$3,711.00
	SR-5W-2-1000	Self-Regulated 16GA Cable, 240V, 5W/linear foot. Sold in 1000' length spools.	\$8,368.00	\$7,421.50
	SR-8W-2-250	Self-Regulated 16GA Cable, 240V, 8W/linear foot. Sold in 250' length spools.	\$2,093.00	\$1,856.00
	SR-8W-2-500	Self-Regulated 16GA Cable, 240V, 8W/linear foot. Sold in 500' length spools.	\$4,185.00	\$3,711.00
	SR-8W-2-1000	Self-Regulated 16GA Cable, 240V, 8W/linear foot. Sold in 1000' length spools.	\$8,368.00	\$7,421.50
120V	SR-K6FT	Self Regulating Kit with Plug, 6ft	\$91.00	\$81.50
	SR-K12FT	Self Regulating Kit with Plug, 12ft	\$132.00	\$108.00
	SR-K18FT	Self Regulating Kit with Plug, 18ft	\$162.00	\$133.50
	SR-K24FT	Self Regulating Kit with Plug, 24ft	\$178.00	\$159.00
	SR-K50FT	Self Regulating Kit with Plug, 50ft	\$339.00	\$279.00
	SR-K75FT	Self Regulating Kit with Plug, 75ft	\$420.00	\$376.00
	SR-K100FT	Self Regulating Kit with Plug, 100ft	\$511.00	\$457.50

PIPE FREEZE PROTECTION CONTROLLERS

Self-regulating cable for indoor and outdoor applications

When combined with an integrated thermostat, the system is automatically turned “on” when temperatures drop below freezing.

Code	Description	Canada	USA
TF115-005	Ambient temperature thermostatic control for Pipe Freeze Protection and Deicing applications. Can be set from 0F to 120F trigger point. Comes with 5ft bulb sensor. 25A (120/208/240V).	\$252.50	\$201.50
TRACE-2	“Plug and Play” controller and power panel for Heat Tracing cables on freeze protection and deicing applications.	\$1,861.00	\$1,534.00

Pipe Heating Accessories

Tools to get the job done right.

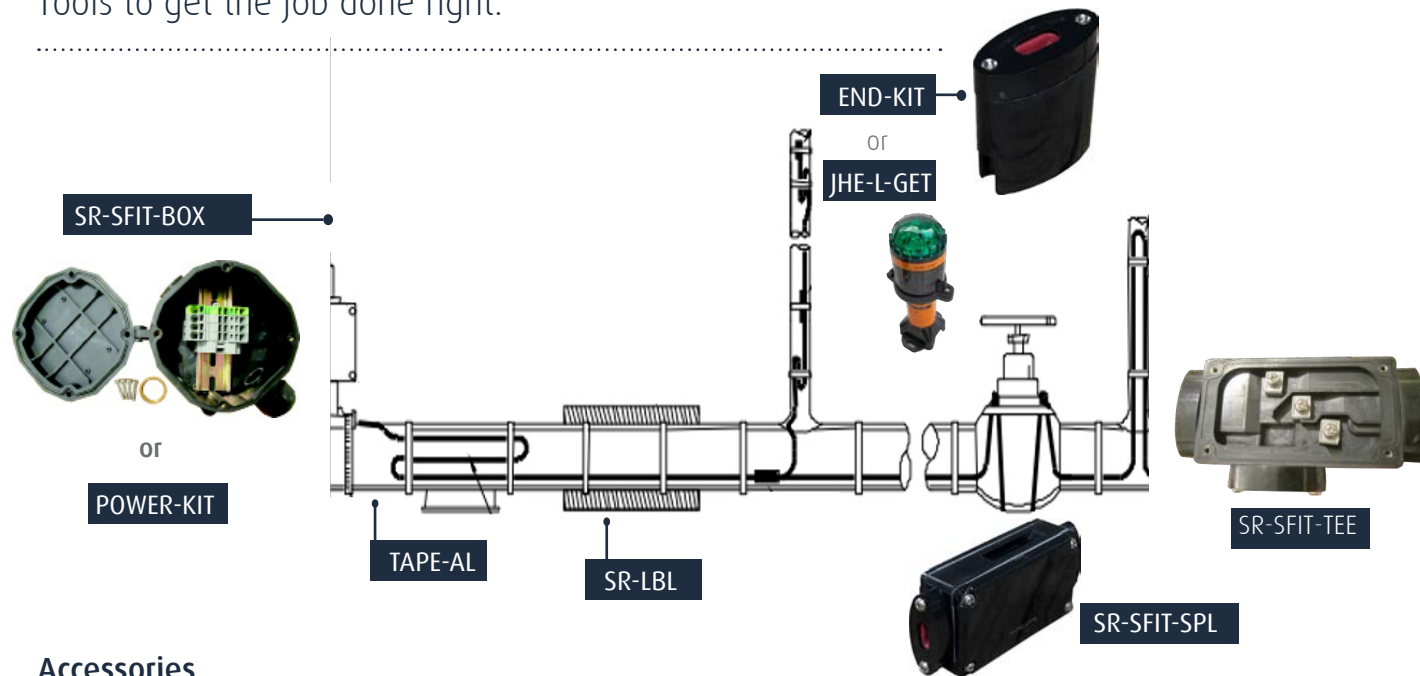

Accessories

Code	Description	Canada	USA
SR-TAPE-AL	Aluminum Foil Tape for Self-Regulating Cable. Sold in 90ft roll.	\$27.00	\$23.00
SR-LBL	Pack of 10 warning lables	\$27.00	\$21.00
SR-ZT-100	Bag of 100 Heavy Duty Zip Ties. 7" long. For use with WSM, WODH and NAMSR cable series. 50lbs load bearing capacity.	\$25.00	\$20.00
POWER-KIT	Power Connection Kit for Self-Regulating Cable. Includes 2" warning labels and 1"END-KIT.	\$87.00	\$69.00
SPLICE-KIT	Splice/Tee Kit for Self-Regulating Cable.	\$58.50	\$46.50
END-KIT	End Seal Kit for Self-Regulating Cable.	\$29.00	\$23.50
SR-SFIT-BOX	Power connection junction box (6x6x3) with Pipe-Mounting Bracket for Self-Reg connections.	\$280.50	\$225.00
SR-SFIT-SPL	In-line splicing box for fast and weathertight connections in the field.	\$89.00	\$70.50
SR-SFIT-TEE	3-Way T-splice box for fast and weathertight connections in the field.	\$96.00	\$76.50
SR-LENDCAP	Lit end cap for self regulating cable	\$355.00	\$283.50
SR-SFIT-PRO	Non-Strip field connection box	\$465.31	\$372.25

INDOOR FREEZE PROTECTION CABLE: UNJACKETED

Most cost-effective solution to protect indoor water lines from freezing

PRODUCT DESCRIPTION

The full range of Warmup UJ self-regulating cable is comprised of the cable in spool format as well as kits, a connection plug-in kit with end seal, and labels. The finished installation may require tape (SR-TAPE-UJ) or a thermostatic plug. The Warmup range offers the key advantage of 5W/linear foot of heat output. This high-output cable provides better results, better protection against frost, all with less cable required. Not suitable for applications in Canada.

PRODUCT CODES

Cables & Kits (120V)

SKU	Description	USA
SR-K6UJ	6' KIT	\$35.50
SR-K12UJ	12' KIT	\$45.50
SR-K18UJ	18' KIT	\$55.50
SR-K24UJ	24' KIT	\$65.50
SR-5W-1-250-U	250' SPOOL	\$631.50



KITS

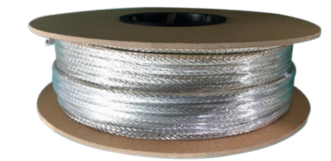

SPOOL

Accessories

SKU	Description	USA
SR-HTMK	Connection and end cap	\$26.00
SR-TAPE-UJ	Application tape (1/2" X 60ft)	\$22.00
SR-PLUG	Simple thermostatic controller to activate at fixed temperature. Switch 16A @ 120V / 12A @ 240V.	\$30.00



SR-HTMK



SR-TAPE-UJ



SR-PLUG

APPLICATION

- Residential Indoor Pipe Protection
- RV/Mobile home applications

CABLE CALCULATION

Determine how much cable you need

Self-regulating cable can be applied in a linear or spiral fashion along the pipe. Self-regulating cable can be overlapped or crossed, though avoid excessive concentration of cable in a confined space (i.e. spooling of cable in single spot). To apply the correct amount of heat to protect the pipe from frost, follow the below multipliers.

Multiply the pipe length by the units below to decide how much cable is required. Example: on a 20ft pipe length in Chicago (-30°F possible ambient) with no insulation, use 20 x 1.5 = 30ft of cable. Apply the cable in an even spiraling fashion along the pipe. For plastic/PVC pipes, double the quantities obtained using the formula above.

For best results, use Warmup's Aluminum Tape (SR-TAPE-UJ) to secure the cable to the pipe.

	Insulation	None	1/2"	1"
1" Pipe	0 ° F Min. Ambient	1	1	1
	-30 ° F Min. Ambient	1.5	1.25	1
2" Pipe	0 ° F Min. Ambient	1.5	1.25	1
	-30 ° F Min. Ambient	2	1.75	1.5



POWER SUPPLY & MAXIMUM CIRCUITS

All UJ cables should be power by 120V supply lines. Based on available amperage or breaker rating, limit the total length of cable on the circuit based on the chart below. Your region's "Minimum Start-up Temperature" will impact your maximum cable length.

(120V)	10A	15A	20A
32 ° F/0 ° C	107	127	133
14 ° F/-10 ° C	95	105	120
0 ° F/-18 ° C	73	93	113
-20 ° F/-30 ° C	60	80	107



Plan for a safe & maintenance-free winter with Warmup®
Roof & Gutter Deicing

Roof and Gutter Deicing



WHY USE A ROOF DEICING SYSTEM ?

When snow piles up on a roof, gravity will take it to the roof edge and into the gutters where it gets stuck. From there, the freeze-thaw cycles of the days and nights will create a 'dam' of ice. Each time that dam grows, it adds more weight onto the gutters that will bend and possibly break.

This can happen in various parts of the roof. The ice can lift shingles and sheet metal during the freezing process, and when it then thaws during the day, water damage can occur. These damages on the roof and the subsequent water damage inside the house can be avoided with a well-designed roof deicing system.

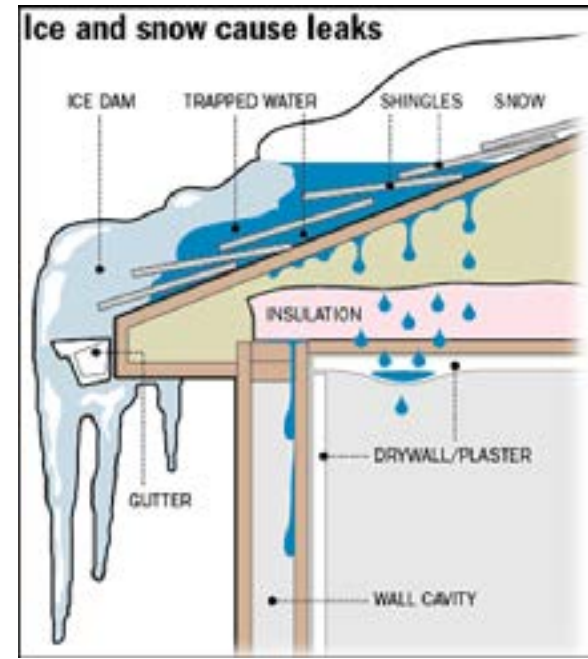

Avoid:

- Hazards from falling ice / snow
- Bended gutters
- Damaged shingles
- Water infiltration
- Drywall damage
- Mold inside the house

WHAT ARE THE WARMUP SOLUTIONS

Warmup offers two types of systems to deice roofs and gutters: a DIY residential solution comprised of plug-in cables (constant wattage WRGH, page 5) and a more comprehensive Self-Regulating cable system for harsh climates (page 7) installed by professionals.

Constant Wattage cables maintain the same output and temperature regardless of the outdoor conditions. These are simpler to specify and install, but may not be suitable for more demanding climates and commercial environments.

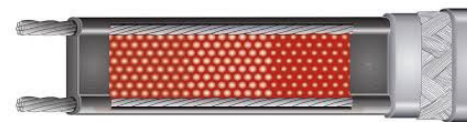

Self-regulating cables are uniquely built for the harshest weather conditions as the cable will increase its output as the temperature gets colder. The inner carbon matrix of the cable will expand and contract with ambient temperatures. The colder it gets, the more it contracts and allows the electricity to flow more rapidly between the conductor cables. While self-regulating, we still recommend connecting these cables to a controller in order to turn them off completely after the last spring frost.



For smaller systems such as a single roof line and downspout or a roof valley where the snow never melts, consider the simplicity of our **plug-in kits**.

What you'll need:

- An outdoor outlet to plug the cable in
- A kit of the right length
- Some roof clips (see Accessories page 8)

HOW TO MEASURE WHAT I NEED ?

To determine the total length of cable needed, measure the various areas to protect. Measure:

- The linear gutters or roofline
- Any valleys (C)
- Any dormers (D)
- And the downspouts (A)

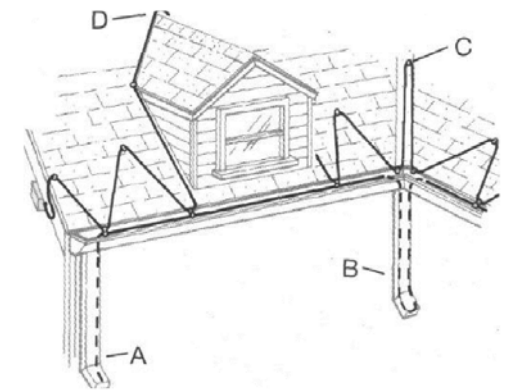

If the downspout is in line with a gutter run, double the length needed since you will be going down the spout and back up to continue the run (B).

If your roof is prone to snow and ice accumulation or if your roof pitch is below 30 degrees (low pitch) we also recommend heating the overhang with "sharkteeth" along the roof line. This is particularly useful in breaking up the accumulated ice and snow and route it to the gutters and down the spouts.

To calculate what you need, take the depth of your overhang (the distance the gutter protrudes from the wall) and plan to run up the roof for 1.5x that distance. So if you have a 2ft overhang, you will go up the roof by 3ft (B) and do so every 2ft (A). Distance A is standard at 2ft but can be modified depending on the type of roof (metal, shingle, etc).

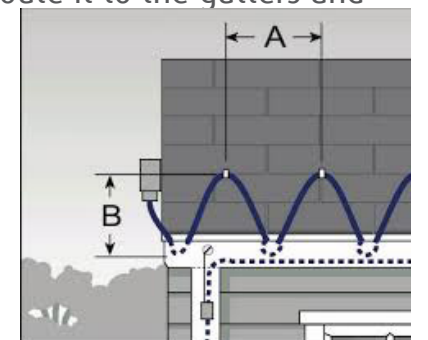

The overhang is unheated and that is why the ice tends to reform over that section of the roof. While the rest of the house is heated and melts the snow, the overhang remains below freezing temperature and requires this additional help to mitigate the ice damming.

To calculate the total amount of cable needed:

CABLE LENGTH = ROOFLINE (ft) / SPACING (ft) x OVERHANG (ft) x 3 + valleys, dormers, and downspouts (see above)

DIFFERENT ROOFS, DIFFERENT NEEDS

Different roof pitches and roofing materials will require appropriate configurations. Accessories like the SB-170 adhesive are also helpful to secure roof clips on metal and rubber roofs that do not allow screwing the clips down. There are many acceptable patterns and layouts for your roof project, but consider the below key principle:

Ensure there is a continuous path from roof to ground

This means that from dormer to valley to roofline and down the spout, you want to ensure the melted ice and snow is progressively removed from your roof. Downspouts should be traced all the way to the ground or below ground as necessary.

ACCESSORIES

Unless you purchase WRGH and SR plug-in kits, you will need an **SR-POWER-KIT** to connect the system to power. Account for one **SR-HANGER-KIT** for each downspout and about 1 bag of **ROOF-CLIP** (50/bag) for each 100ft of cable. Roof clips can be screwed under the shingles or applied with **SB-170 adhesive**. The latter is also the preferred method on non-standard roofs, metal roofs and rubber roofs.

ELECTRICAL PROVISIONS

Once you have determined your total cable length it possibly needs to be broken down in multiple circuits. For example, you can put up to 165ft of 5-watt cable on a 120 volt / 20A breaker, or up to 330ft of cable on a 240V/20A breaker. Refer to Spec Sheet WSC-0929 for maximum circuit runs based on voltage and amperage available.

Finally, Warmup highly recommends a controller to automatically turn off your system when temperatures are safely above freezing. This is to maintain a long product life and prevent unnecessary power usage during the warmer months. Common choices are the **ASE-DS8** or the **TRF-115** available on page 8.

For Plug-in Kits, automatic shut-off is also possible with the **SR-PLUG**.

PROJECT EXAMPLE

Roof Run Length	60'	60' of cable for the total Roof Run Length +
Overhang	2'	60' / 3' = 20, 20 x 3' = 60' of cable to make 20 3' triangles +
Number of Downspouts	3	15' x 2 = 30', 30' x 3 = 90' of cable to heat 3 15' downspouts =
Downspout Length	15'	210' of cable required per recommended heating guidelines



Warmup® Solutions



	SR	WRGH
Cable	SR-5W-1-250	WRG-120-1200
Control	ODC-ASE-DS8C	ODC-WRS-2
Accessories	Hanger kits, Power Kit, Roof Clips, and SB-170	Included with kit
Total Cost	\$ 2,133.00	\$459.00

ROOF & GUTTER DE-ICING SYSTEMS

Constant Wattage Plug-In Kits for Residential Applications

The Warmup WRGH is a constant wattage roof de-icing system supplied in pre-terminated plug-in kits. It is offered in sizes from 30ft to 240ft, from 150W to 1,200W. It is supplied with roof clips and spacers. WRGH kits are sold pre-assembled with a 3-prong plug in order to provide a simple, DIY solution to resolve ice dams and snow accumulation on roof lines.

While spacing will impact the eventual output, the WRGH cables are designed for residential use.

For heavy-duty and commercial applications, please refer to the SR product range from Warmup.

An optional WRS-2 Controller can be purchased to reduce usage and electrical draw when temperatures are above 40°F. It is highly recommended, to increase product life and to reduce risk of fires or burn outs.



TECHNICAL SPECIFICATIONS

- Not suitable for Pipe Freeze Protection
- Do not overlap or terminate cable
- Turn system off after the snow season
- Must be connected to GFCI protected outlet or breaker.



WRS-2 Controller

Code	Length in Feet	Wattage	Voltage	W/lin. ft	Canada	USA
WRGH-120-150	30	150	120	5	\$113.00	\$92.50
WRGH-120-300	60	300	120	5	\$145.00	\$119.00
WRGH-120-400	80	400	120	5	\$185.00	\$151.50
WRGH-120-500	100	500	120	5	\$205.00	\$168.00
WRGH-120-600	120	600	120	5	\$260.00	\$212.50
WRGH-120-800	160	800	120	5	\$304.00	\$248.00
WRGH-120-1000	200	1000	120	5	\$366.00	\$299.00
WRGH-120-1200	240	1200	120	5	\$399.00	\$325.50

Code	Description	Canada	USA
ODC-WRS-2	Moisture & Temperature Controller for Warmup WRG Roof & Gutter De-icing Kits.	\$159.00	\$133.50

ROOF AND GUTTER DE-ICING SYSTEMS

Self-regulating Cable for Harsh Climates and Demanding Environments

Warmup's self-regulating roof de-icing cables are heavy-duty cables that will ensure performance under the most challenging conditions. Ice dams can lead to water seeping and interior damage, falling ice and snow on sidewalks.

We have designed the right systems to protect your roofs, gutters and downspouts from damage or injury caused by ice.

Our self-regulating cable will vary its output based on ambient temperature. This reduces consumption costs by requiring just the amount of heat needed to get the job done.

With simple plug-in kits for residential use and large spools for engineered systems and commercial buildings, we look forward to being a part of your project.

FEATURES & BENEFITS

- Self-regulating cable for cost-efficient operation
- Automatic controls to trigger heating only when needed
- Fits on all roof types with a full range of accessories
- Carries a 10-year warranty

TECHNICAL SPECIFICATIONS

- Commercial Grade, 16 AWG Buss Wire
- Standard Braid with overjacket for wet & dry locations
- Circuit lengths up to 540ft
- 5W or 8W/ft output at 50°F
- Available in 120V and 208-277 Volts

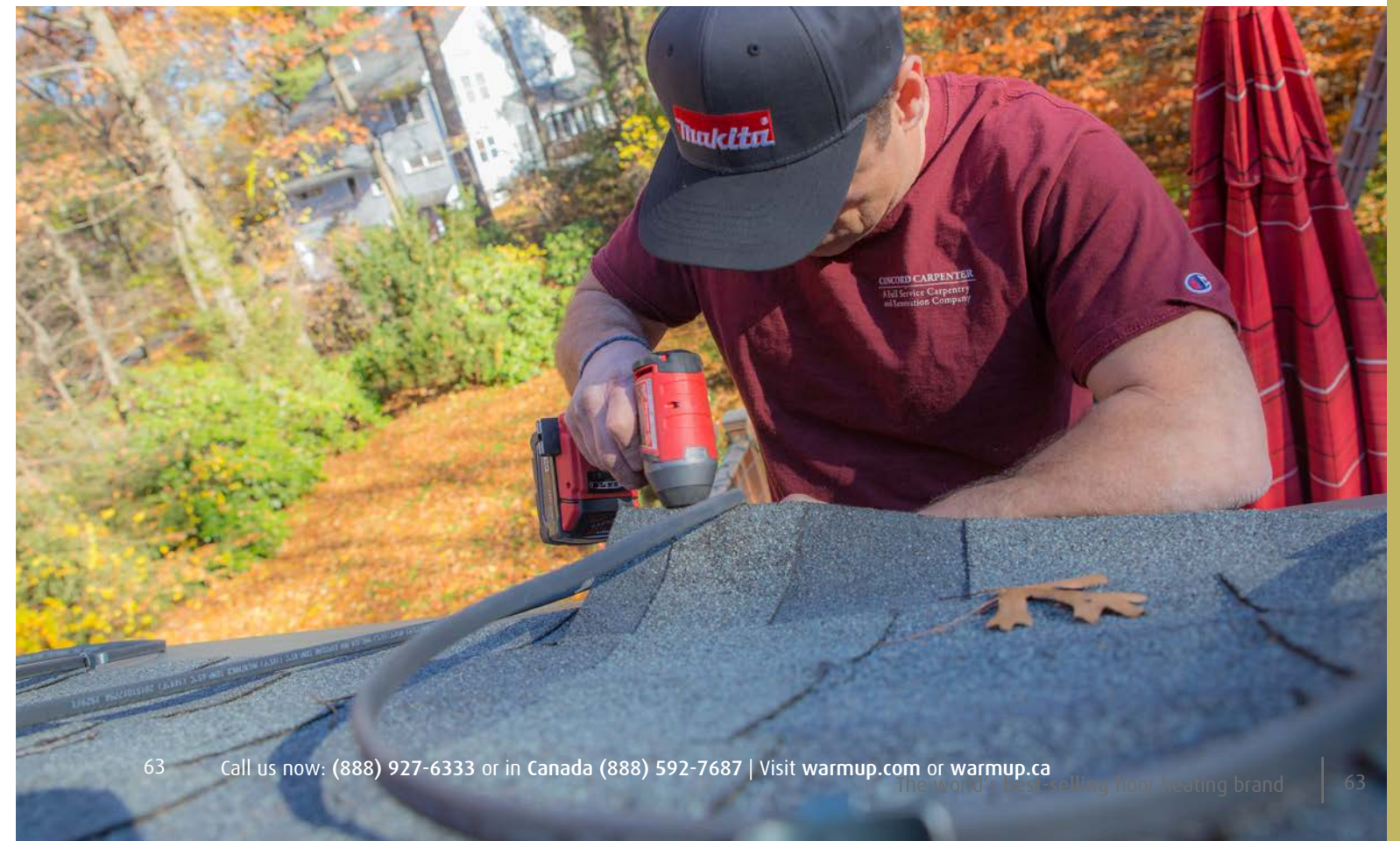

	Code	Description	Canada	USA
120V	SR-5W-1-250	Self-Regulated 16GA Cable, 120V, 5W/linear foot. Sold in 250' length spools.	\$2,033.00	\$1,803.00
	SR-5W-1-500	Self-Regulated 16GA Cable, 120V, 5W/linear foot. Sold in 500' length spools.	\$4,065.00	\$3,605.00
	SR-5W-1-1000	Self-Regulated 16GA Cable, 120V, 5W/linear foot. Sold in 1000' length spools.	\$8,129.00	\$7,210.00
120V	SR-8W-1-250	Self-Regulated 16GA Cable, 120V, 8W/linear foot. Sold in 250' length spools.	\$2,033.00	\$1,803.00
	SR-8W-1-500	Self-Regulated 16GA Cable, 120V, 8W/linear foot. Sold in 500' length spools.	\$4,065.00	\$3,605.00
	SR-8W-1-1000	Self-Regulated 16GA Cable, 120V, 8W/linear foot. Sold in 1000' length spools.	\$8,129.00	\$7,210.00
240V	SR-5W-2-250	Self-Regulated 16GA Cable, 240V, 5W/linear foot. Sold in 250' length spools.	\$2,093.00	\$1,856.00
	SR-5W-2-500	Self-Regulated 16GA Cable, 240V, 5W/linear foot. Sold in 500' length spools.	\$4,185.00	\$3,711.00
	SR-5W-2-1000	Self-Regulated 16GA Cable, 240V, 5W/linear foot. Sold in 1000' length spools.	\$8,368.00	\$7,421.50
	SR-8W-2-250	Self-Regulated 16GA Cable, 240V, 8W/linear foot. Sold in 250' length spools.	\$2,093.00	\$1,856.00
	SR-8W-2-500	Self-Regulated 16GA Cable, 240V, 8W/linear foot. Sold in 500' length spools.	\$4,185.00	\$3,711.00
120V	SR-8W-2-1000	Self-Regulated 16GA Cable, 240V, 8W/linear foot. Sold in 1000' length spools.	\$8,368.00	\$7,421.50
	SR-K6FT	Self Regulating Kit with Plug, 6ft	\$91.00	\$81.50
	SR-K12FT	Self Regulating Kit with Plug, 12ft	\$132.00	\$108.00
	SR-K18FT	Self Regulating Kit with Plug, 18ft	\$162.00	\$133.50
	SR-K24FT	Self Regulating Kit with Plug, 24ft	\$178.00	\$159.00
	SR-K50FT	Self Regulating Kit with Plug, 50ft	\$339.00	\$279.00
	SR-K75FT	Self Regulating Kit with Plug, 75ft	\$420.00	\$376.00
	SR-K100FT	Self Regulating Kit with Plug, 100ft (see below)	\$511.00	\$457.50



CONTROLS AND ACCESSORIES

A wide variety of control options to fit any size roof and gutter heating project.

Controllers

Code	Description	Canada	USA
ODC-ASE-DS8C	Wall-mounted controller with built-in sensor and 1x30A capacity (240V). For Snow Melting.	\$869.00	\$695.50
ODC-ASE-DS9C	Wall-mounted controller with built-in sensor and 2x30A capacity (240V). For Snow Melting.	\$1,118.00	\$894.50
ODC-RESIBOX3	Automatic Snow Melting Panel with 3 x 30A switching capability and integrated GFEP protection. Requires AIRSENSE sensor.	\$4,908.00	\$4,097.50
ODC-AIRSS	Outdoor moisture and temperature sensor.	\$1,055.00	\$843.50
ODC-AIRSS-B	Mounting bracket for AirSense sensor.	\$267.00	\$213.50



Accessories

Code	Description	Canada	USA
HANGER-KIT	Downspout Hanger for Self-Regulating Cable and Roof/Gutter heaters.	\$28.00	\$21.00
POWER-KIT	Power Connection Kit for Self-Regulating Cable. Includes 2*warning labels and 1*END-KIT.	\$86.00	\$69.00
ROOF-CLIP	Metal single roof clips packaged and sold 50 per pkg. Secure to roof with screws or Everseal SB-170 adhesive or similar.	\$144.00	\$115.50
SB-170	Versatile adhesive to apply the Warmup ROOF-CLIP on a variety of roof structures. It is water and weather proof with a strength of 2,000 psi.	\$44.00	\$35.00
SR-SPLICEKIT	Splice/Tee Kit for Self-Regulating Cable.	\$58.50	\$46.50
END-KIT	End Seal Kit for Self-Regulating Cable.	\$29.00	\$23.50
CRDS-15-GFI	6ft lead with GFCI 3-prong molded plug, NEMA 5-15, 15 amp, 14/3.	\$111.00	\$91.00

SpeedFit Accessories

Code	Description	Canada	USA
SR-SFIT-BOX	Power connection junction box (6x6x3) with Pipe-Mounting Bracket for Self-Regulating connections.	\$280.50	\$225.00
SR-SFIT-SPL	In-line splicing box for fast and weathertight connections in the field.	\$89.00	\$70.50
SR-SFIT-TEE	3-Way T-splice box for fast and weathertight connections in the field.	\$96.00	\$76.50
SR-SFIT-PRO	Non-Strip field connection box (see more on page 65).	\$465.31	\$372.25



Warmup[®]

The world's **best-selling** floor heating brand™



Warmup Inc.
USA

T: (888) 927-6333
F: (888) 927-4721

www.warmup.com
ussales@warmup.com



Warmup Inc.
Canada

T: (888) 592-7687
F: (888) 927-4721

www.warmup.ca
ca@warmup.com



Warmup Inc.
Mexico

T: +52 (55) 8114 0145
o +52 (55) 8114 0146

www.warmup.com.mx
mexico@warmup.com

QUESTIONS / QUOTES

ussales@warmup.com

For sales support and quotes in just 24 hours, contact us at ussales@warmup.com

TECHNICAL

warmupedia.warmup.com

Warmupedia documents installation tips and troubleshooting guides for all Warmup products.